

PacificWave Update and Future Directions



John Silvester

***University of Southern California
Chair, CENIC***

APAN20, Taipei, 2005.08.24

Overview

- Introduction to Pacific Wave
- Current Status including recent additions
- NSF/IRNC Projects and PacificWave
- Involvement in iGRID05 (San Diego) and SC05 (Seattle)
- Future plans and directions

What is Pacific Wave?



Pacific Wave is a state-of-the-art international peering and lambda integrated facility designed to serve advanced research, education, development, and high-tech networks throughout the Pacific Rim and the world.

Goal: enhance networking capabilities by increasing network efficiency, reducing latency, increasing throughput, reducing costs and provision point-to-point lambda services to meet the short and long-term needs associated with advanced application and network development and implementation.

Global R&E Network Pathways

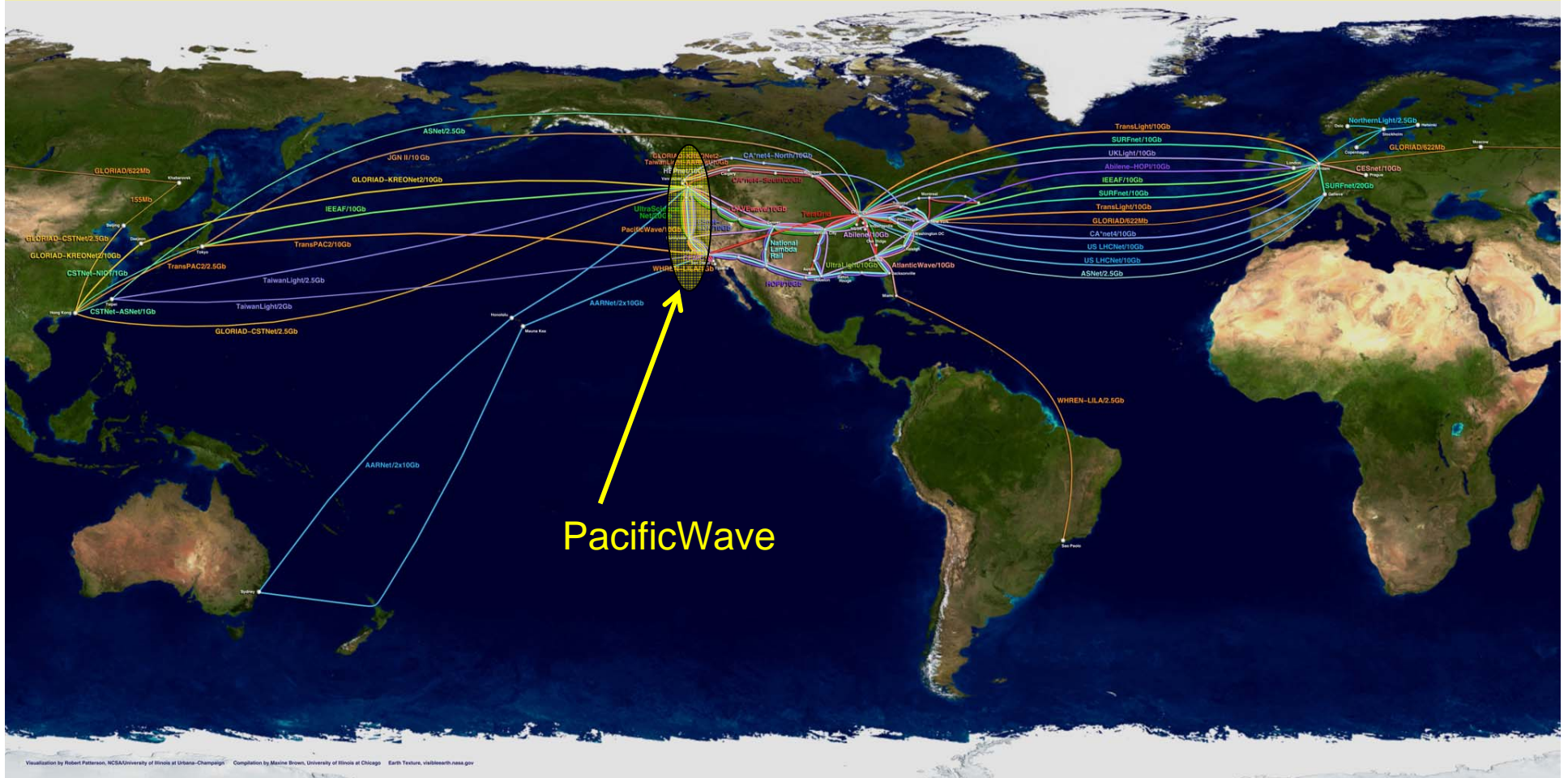

http://www.glif.is/gfx/GLIF_2048-03August2005.jpg

DISCLAIMER - This network map was a best estimate of connectivity around August 2005.

APAN20-PacificWave, 2005.08.24

Pacific Wave Today



- Extensible peering exchange and lambda integrated facility
- Nodes (currently) in Seattle, Sunnyvale, and Los Angeles, connected by a 10GbE wave provisioned over CalREN and National LambdaRail (2,241 kilometers)
- AUP free
- Supports IPv4 and IPv6; multicast enabled
- Based on Layer 2, Ethernet connections (for layer 3 peering)
- Provides 24x7 NOC support.
- Priced consistently from node to node
- Allows participants to self-select their peering
- Allows participants to connect to one-location and access participants at all Pacific Wave nodes
- Supports advance applications
- Welcomes any research or development network that can meet the minimum network configuration requirements (connect with a router; support BGP; support jumbo-frames)

Who Operates Pacific Wave?

A joint project of CENIC and Pacific Northwest Gigapop

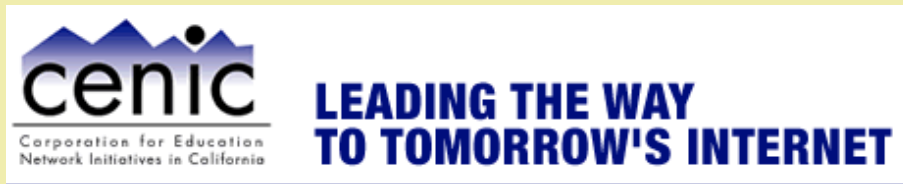

In collaboration with University of Southern California and University of Washington



Overview

- Introduction to Pacific Wave
- **Current Status including recent additions**
- NSF/IRNC Projects and PacificWave
- Involvement in iGRID05 (San Diego) and SC05 (Seattle)
- Future plans and directions

PacificWave Seattle

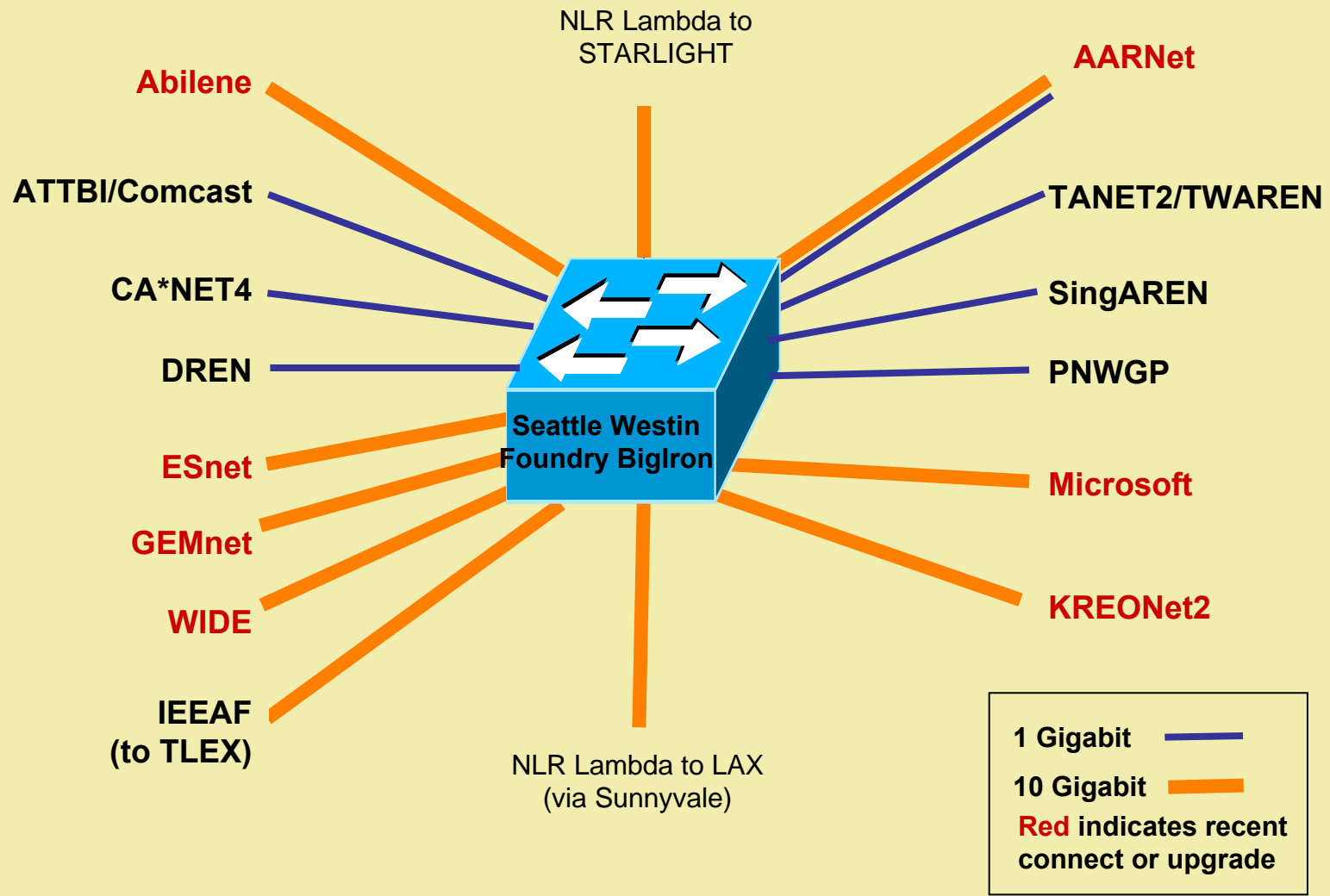

Pacific Wave - Sunnyvale

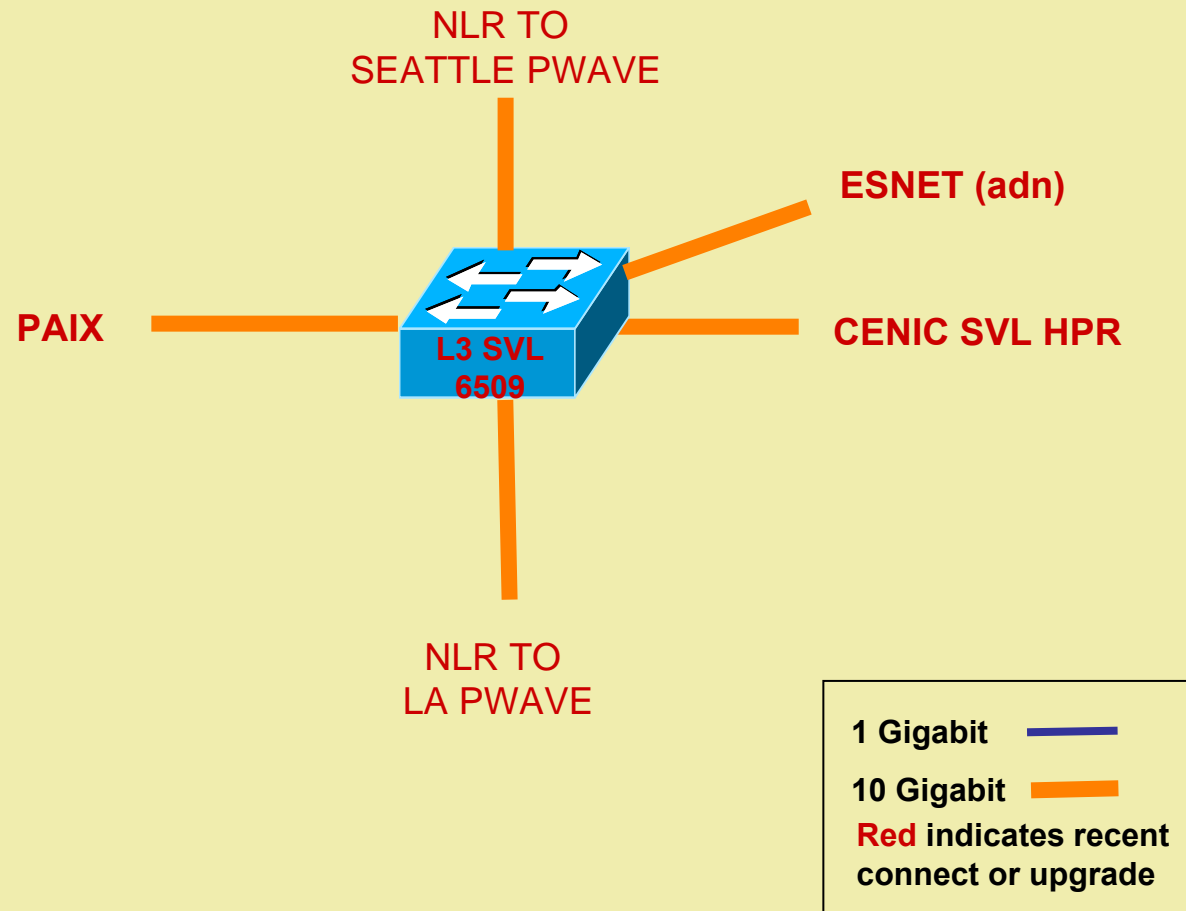

Pacific Wave - Los Angeles

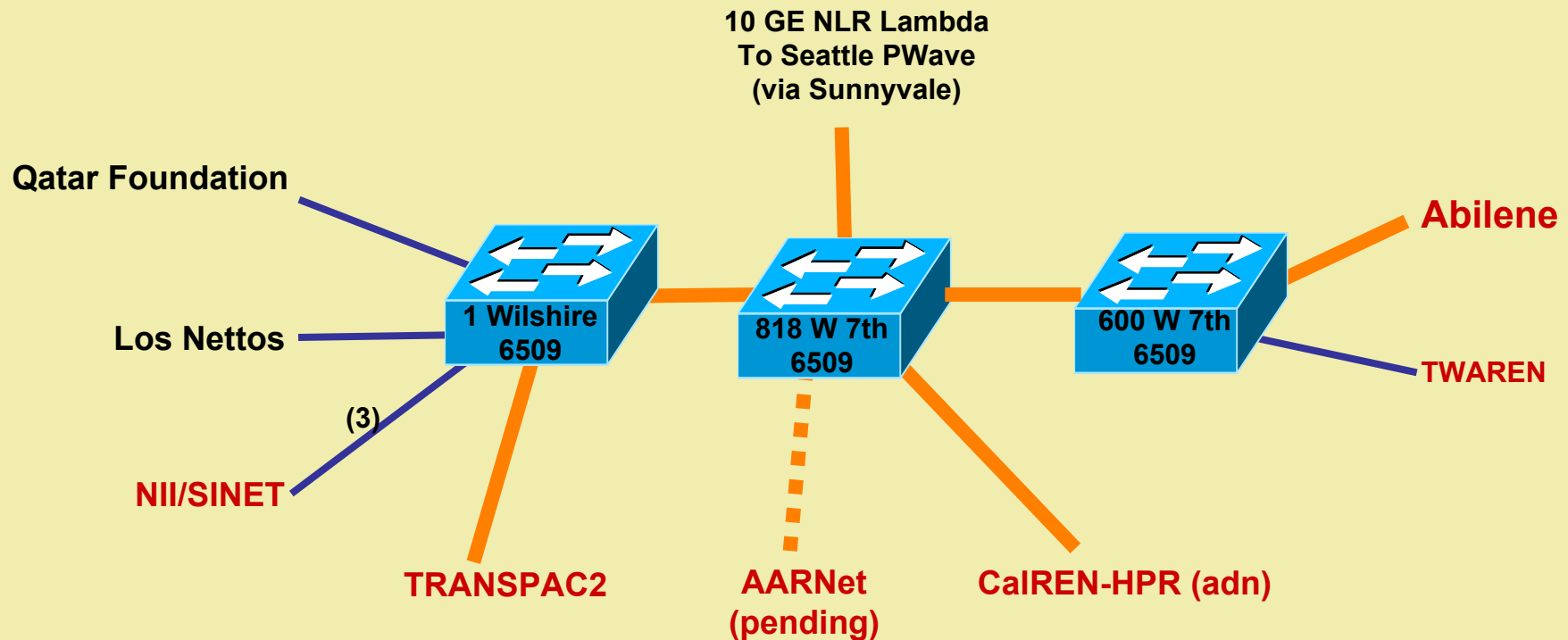

Any Day Now
Singaren at 1G
Mimos Berhad at 1G

1 Gigabit ———
10 Gigabit ———
Red indicates recent
connect or upgrade

Overview

- Introduction to Pacific Wave
- Current Status including recent additions
- **NSF/IRNC Projects and PacificWave**
- Involvement in iGRID05 (San Diego) and SC05 (Seattle)
- Future plans and directions

NSF-IRNC Projects

- Gloriad – Global Ring: China, Korea, Russia, US
- Translight/PacificWave – PacificWave exchange, AARnet links, Hawaii connectivity
- Translight/StarLight – Europe
- Transpac2 – US-Japan and beyond
- WHREN/LILA – South America

Gloriad, AARnet, Transpac2, all use PacificWave and WHREN plans to do so and PacificWave plans to bridge to Chicago (Starlight)



Translight/PacificWave (TL/PW)

- NSF/SCI/IRNC Award #0441119
 - PI John Silvester (USC)
 - Co-PI Ron Johnson (UW)
- Objectives
 - Build out PacificWave exchange capabilities to facilitate international R&E connections on US Pacific Coast
 - Assist in the termination of AARnet SXTransport links to SEA and LAX
 - Assist in buildout of Hawaii connectivity
 - Assist in operation of IEEAF link Tokyo-Seattle
 - Provide ongoing engineering and technical support to international networks landing at PacificWave nodes
 - Develop and operate advanced capabilities to support optical interconnect and exchange needs of R&E networks

TL/PW Pacific Connections

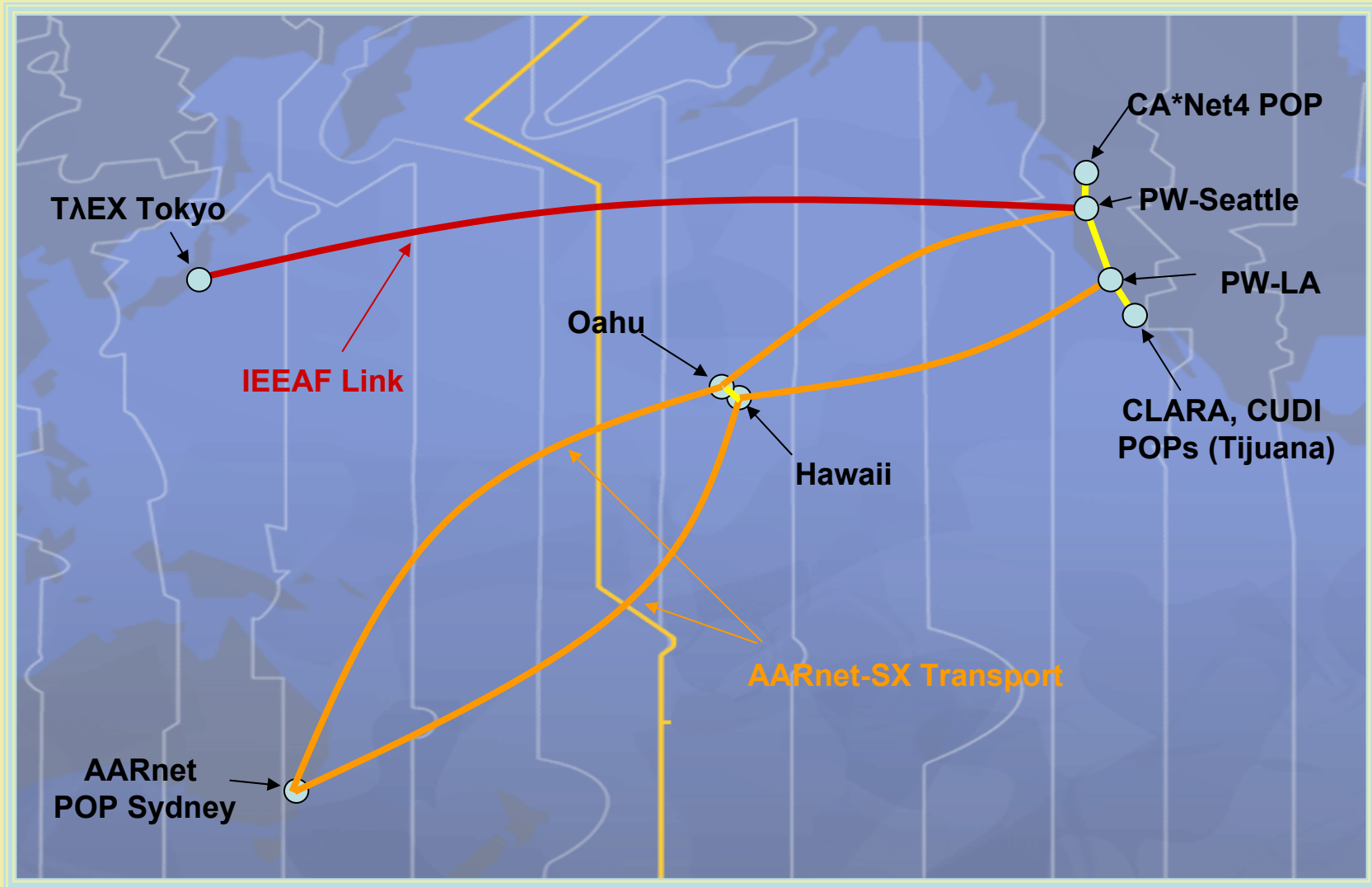

TL-PW – West Coast Detail

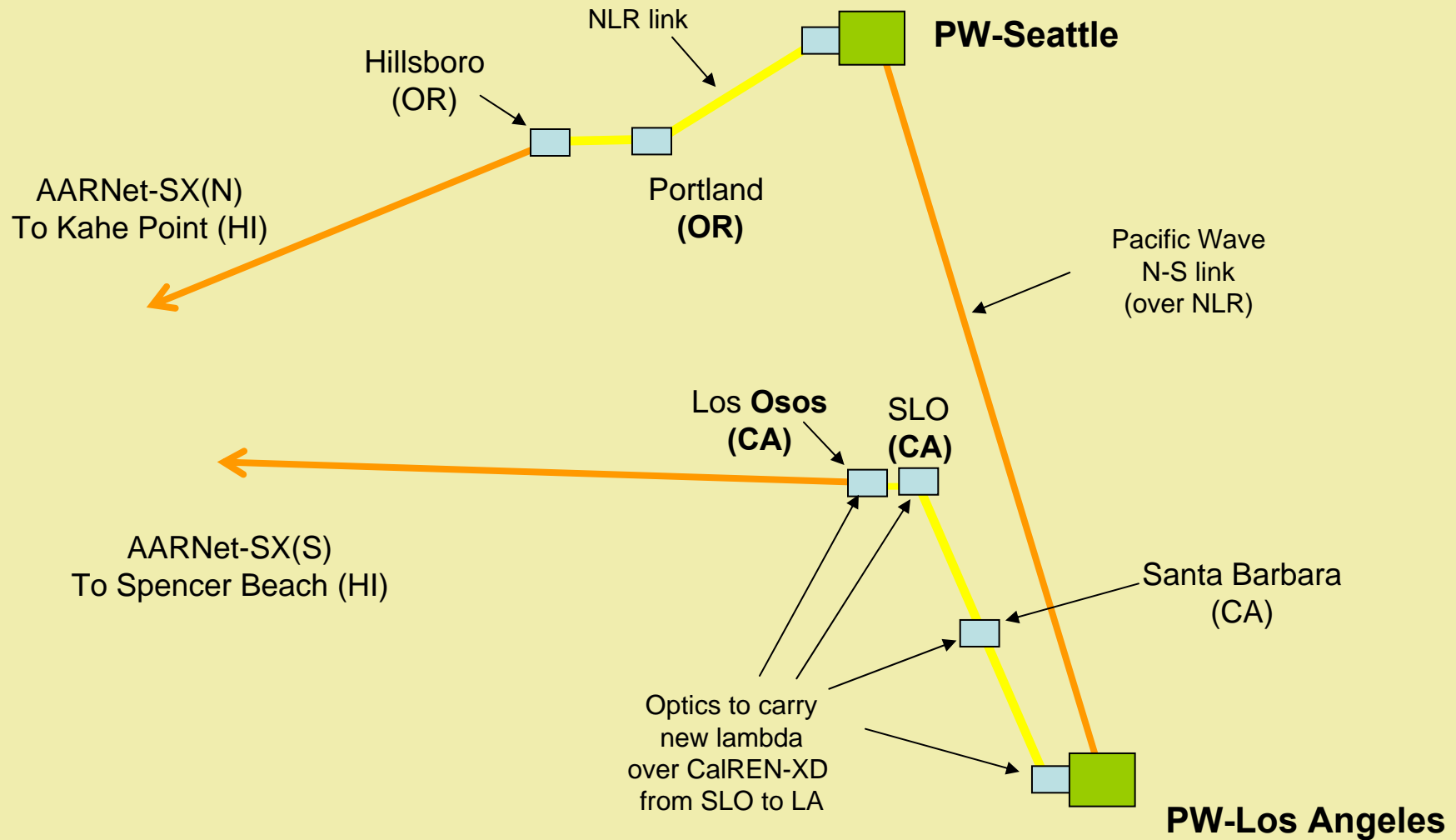

TL/PW – Hawaii Detail

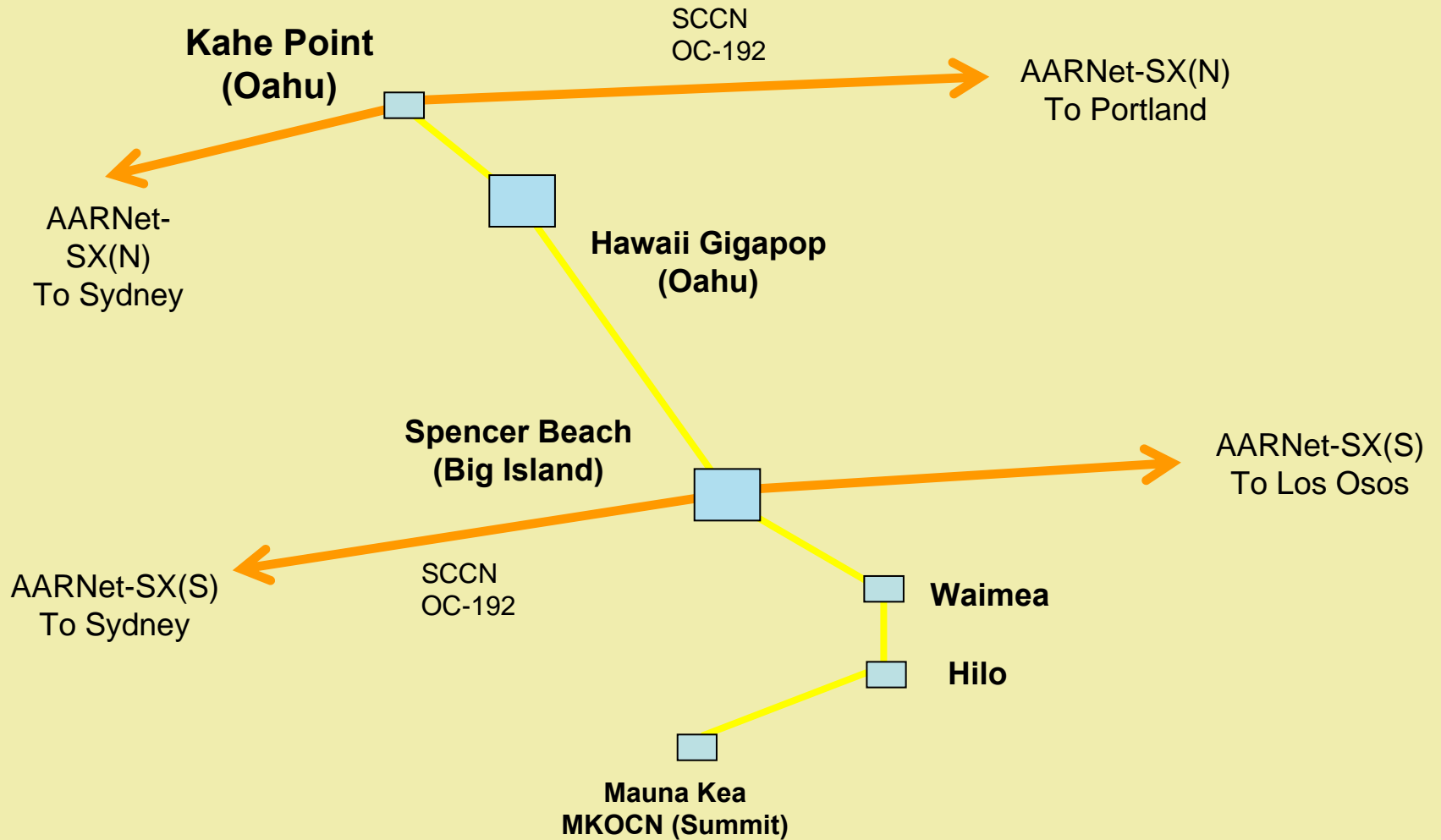

WHREN/LILA

- NSF/SCI/IRNC Award #0441095
 - PI Julio Ibarra (FIU)
 - Co-PIs, Heidi Alvarez (FIU), Chip Cox (FIU), John Silvester (for CENIC)
- Objectives
 - Enhance connectivity from US to Latin America
 - Fiber link across US-MEX border from San Diego to Tijuana and interconnect to CLARA and CUDI
 - Link from Miami to Sao Paulo

WHREN-LILA links with RedCLARA

MIA-Sao Paulo and San Diego-Tijuana

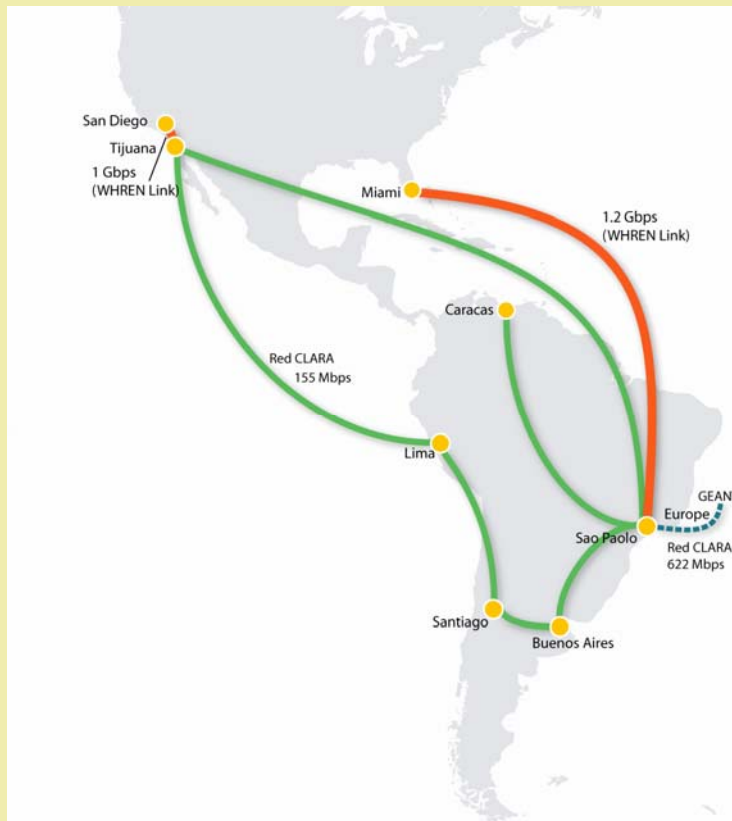

WHREN-LILA Year 1 Link San Diego – Tijuana

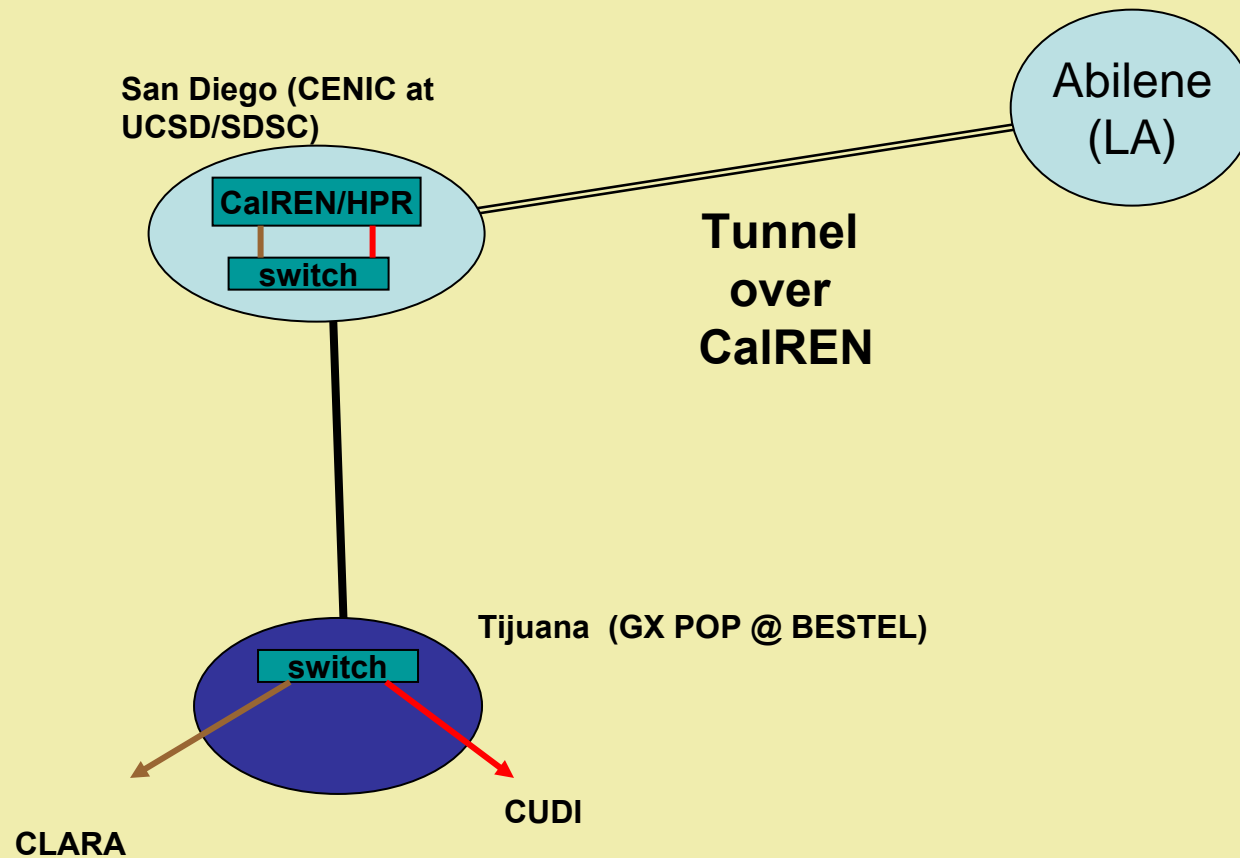

Plans to migrate to a direct connection into Pacific Wave for CUDI and CLARA

Overview

- Introduction to Pacific Wave
- Current Status including recent additions
- NSF/IRNC Project and PacificWave
- Involvement in iGRID05 (San Diego) and SC05 (Seattle)
- Future plans and directions

iGrid and Supercomputing

- Two major conferences on US West Coast in 2005.
- iGrid at UCSD (CALIT2) in September, and SC'05 in Seattle (November)
- PacificWave is collaborating with many international networks and research groups to facilitate their demos at these events
- PacificWave, CENIC, and PNWG are providing significant bandwidth

iGRID

- Focus on applications demanding advanced networking
- To be held at CALIT2 at University of California San Diego, September 2005
- Many experimental demos

iGRID 2005

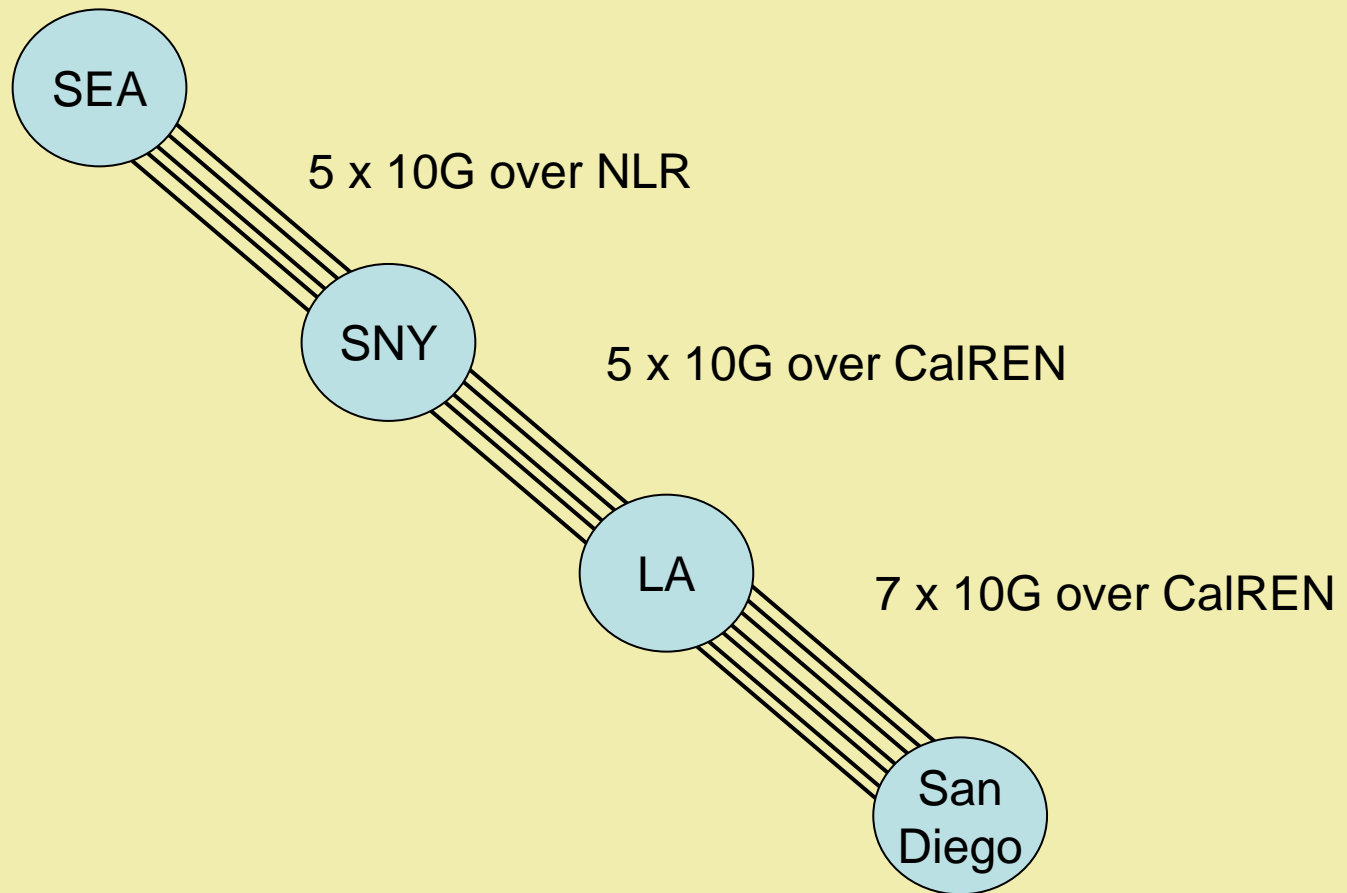

Supercomputing 2005

- The Annual Supercomputing event
- Last year in Pittsburgh there were 17x10G connections coming into the show floor
- This year there are ~50, several supported by PacificWave

Supercomputing 2005 (not final)

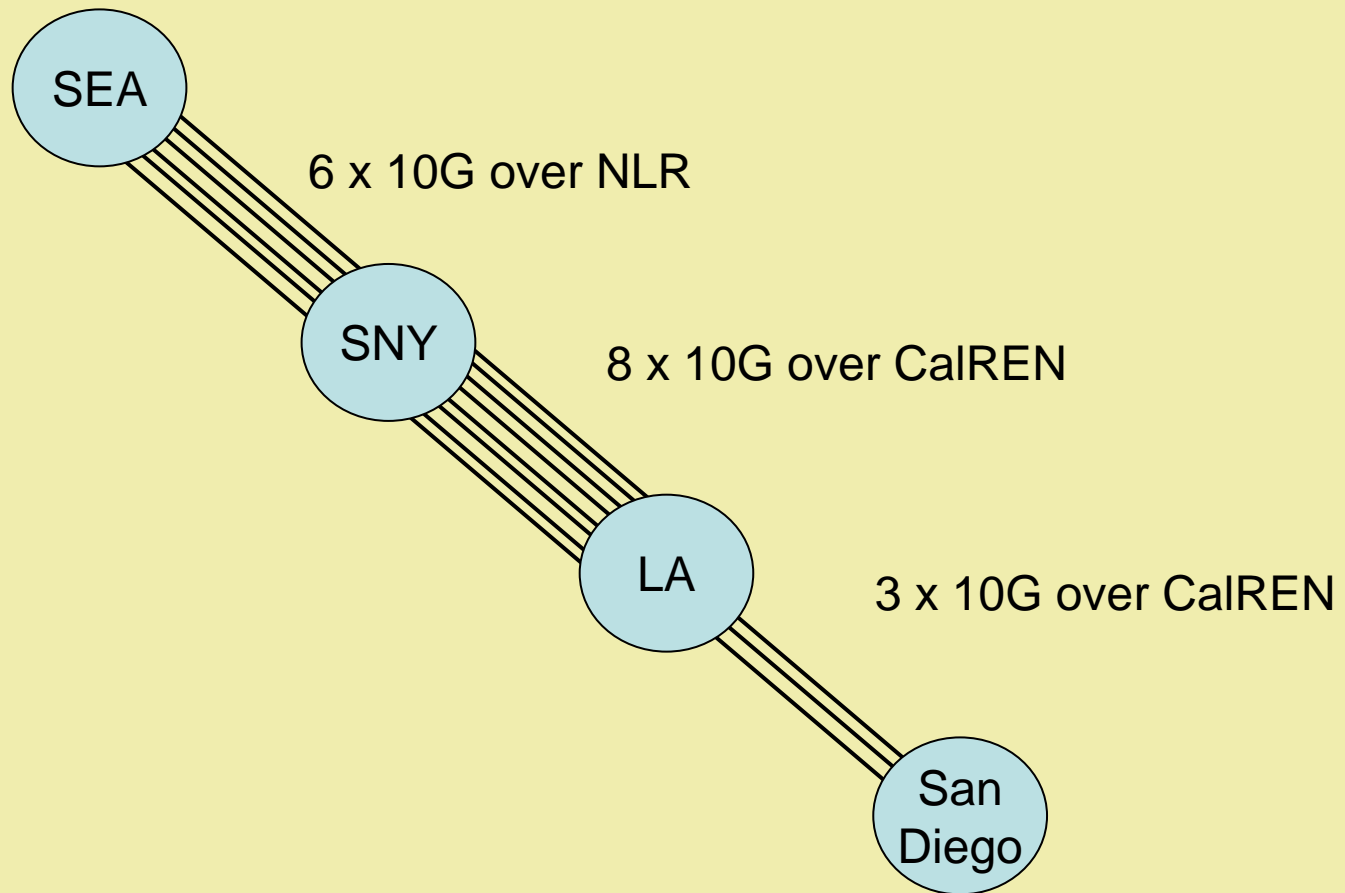

Overview

- Introduction to Pacific Wave
- Current Status including recent additions
- NSF/IRNC Project and PacificWave
- Involvement in iGRID05 (San Diego) and SC05 (Seattle)
- Future plans and directions

Pacific Wave – What's Next?



- Bring up the Southern AARnet link – 2005-Q3
- Other connections as requested
- Migrate WHREN connections to participate in PacificWave directly (depends on funding)
- Extend PacificWave to Starlight (Chicago) to facilitate direct peering with European networks.
- Need for more flexible interconnect (layer 2, layer 1, optical) and ability to manage these interconnect dynamics and complexity more efficiently. Driven by iGRID and SC'-05, also NLR, HOPI, GLIF, UCLP.
- New website coming soon – up by iGRID
www.pacificwave.net