

Towards a Green Internet

Rod Tucker

ARC Special Research Centre for
Ultra-Broadband Information Networks (CUBIN)
University of Melbourne



Energy and the Internet

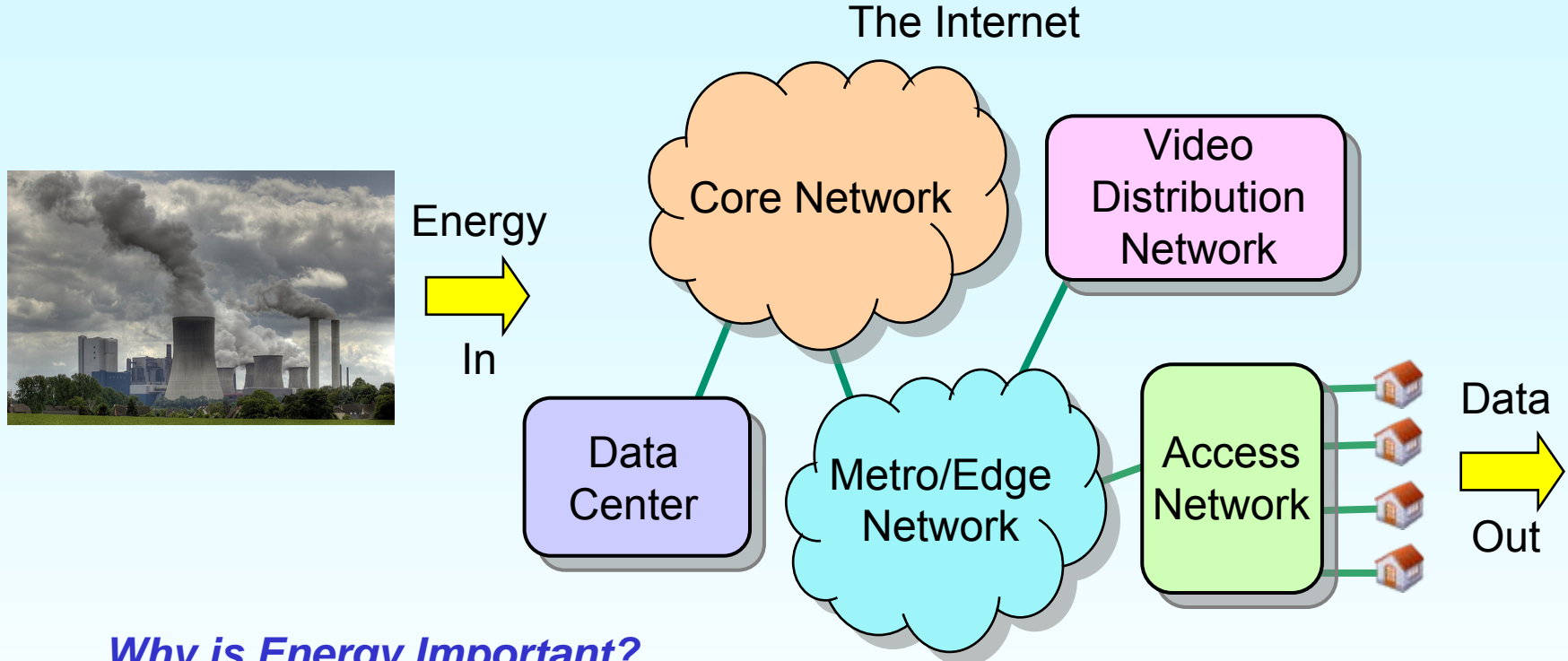

Why is Energy Important?

- Operational Expenditure
- Greenhouse Impact
- Energy-limited capacity bottlenecks (“hot spots”)
- Enabling energy efficiencies in other sectors

Putting Things into Context

Information and Communication Technologies (ICT)

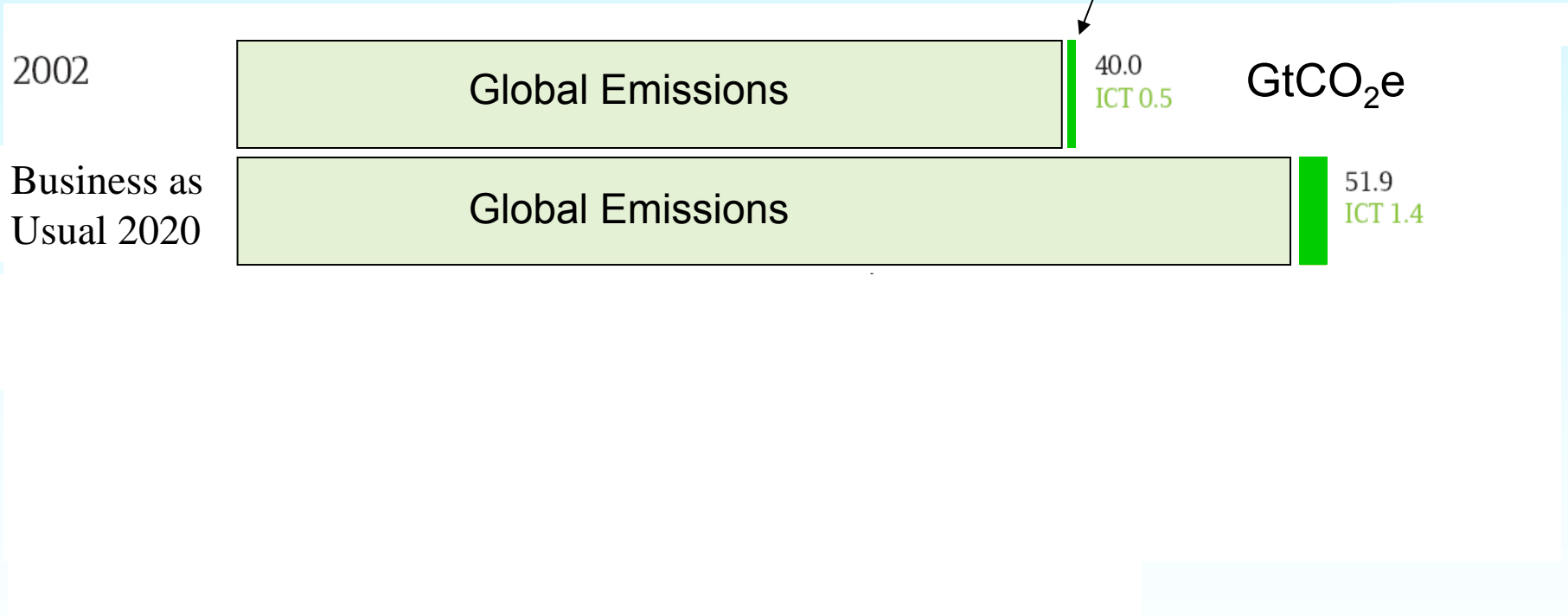

“SMART 2020: Enabling the low carbon economy in the information age,”
GeSI, 2008 www.gesi.org



Summary

- Estimating energy consumption of the Internet
- Where is the energy consumed
 - Core, metro, access network
- Energy efficiency of Cloud Computing
- Travel Replacement
- Airmail vs. Internet



Network Energy Model

Tier 1 Network

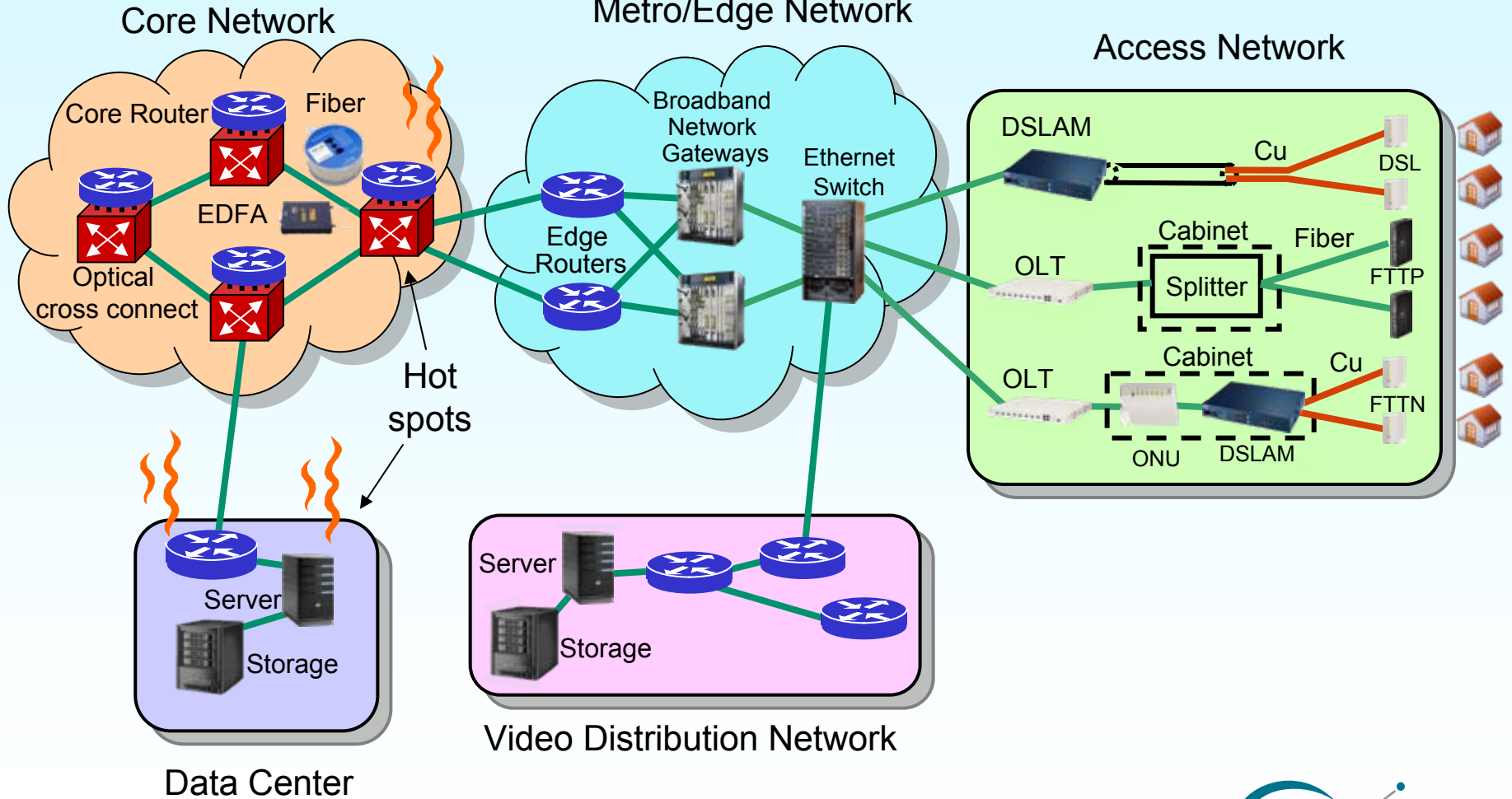

Power Consumption of IP Network

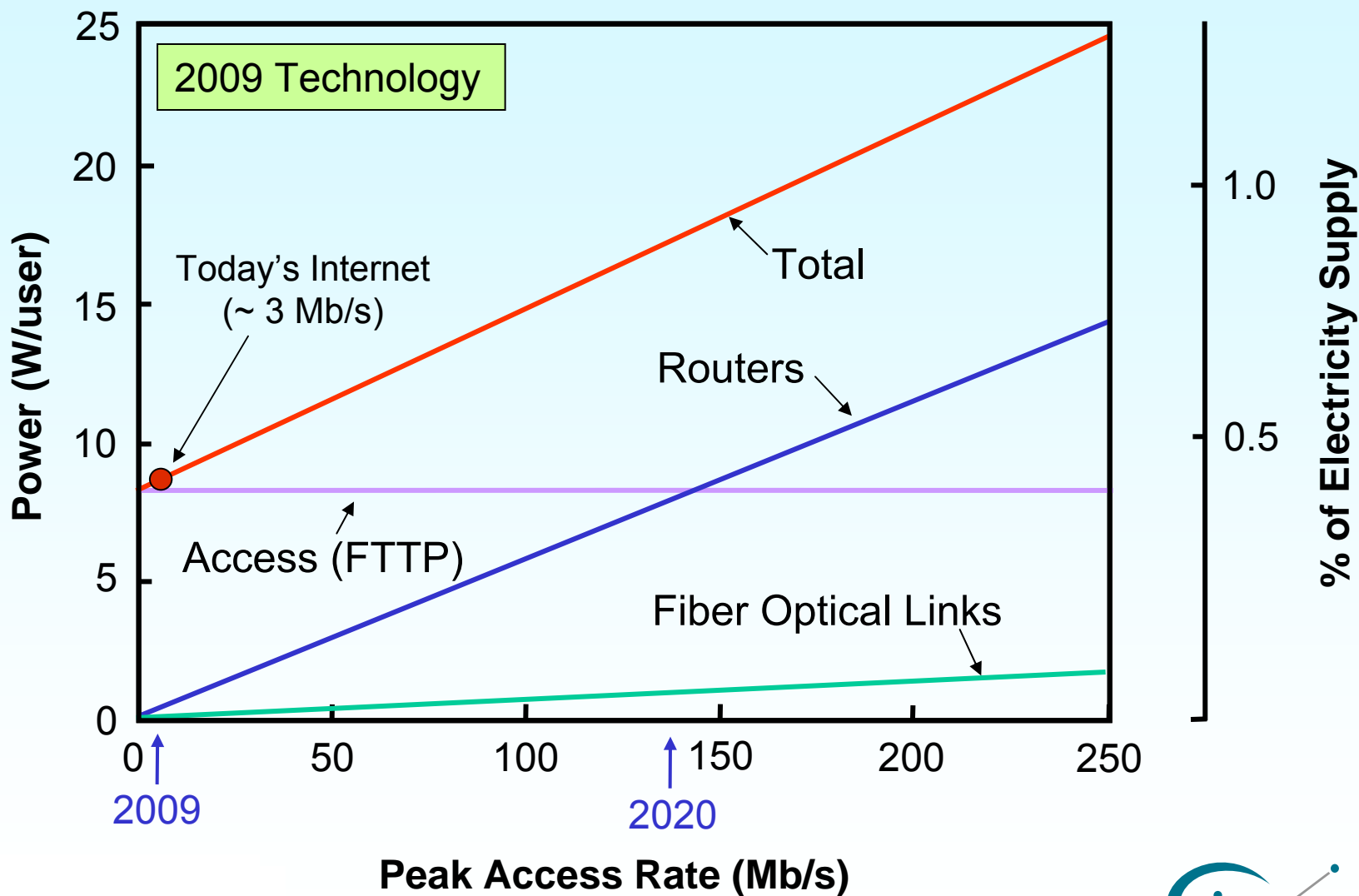

Traffic Growth = 40% p.a

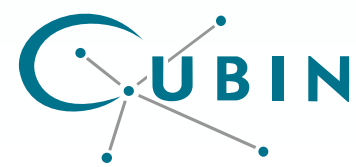

Power Consumption in Access Networks

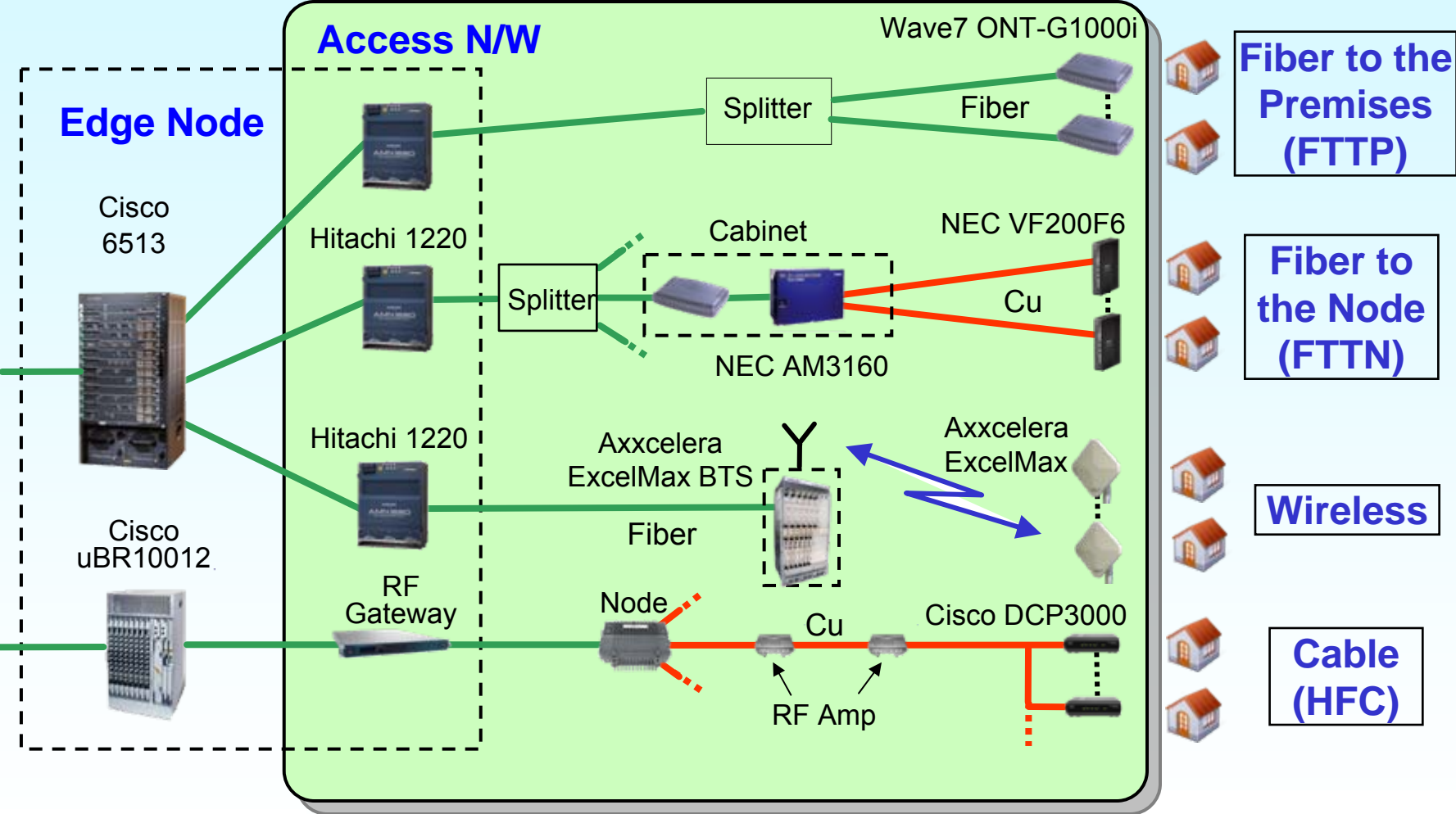

Power Consumption in Access Networks

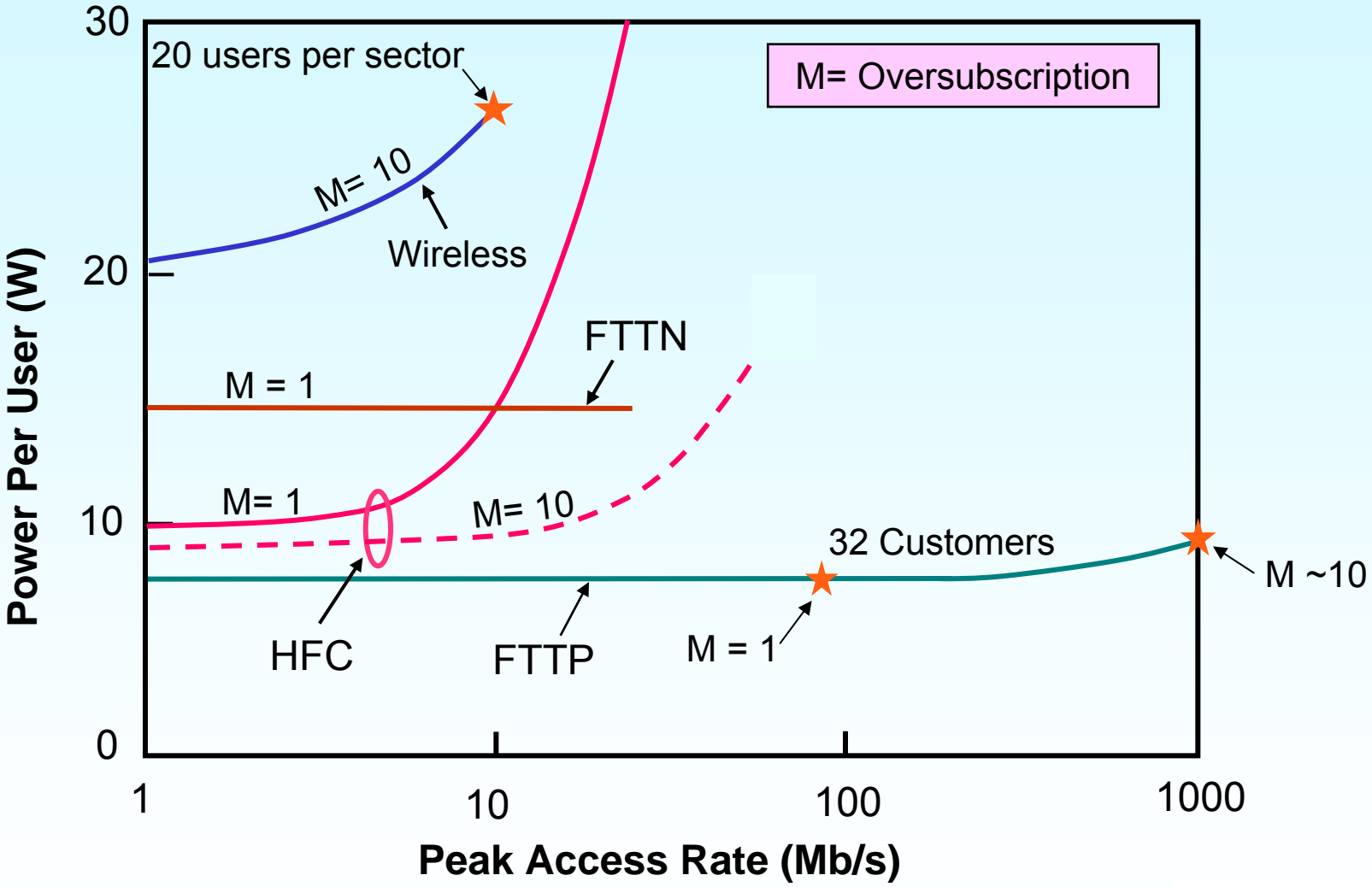

FTTP is "greenest"

Network Energy Consumption per Bit

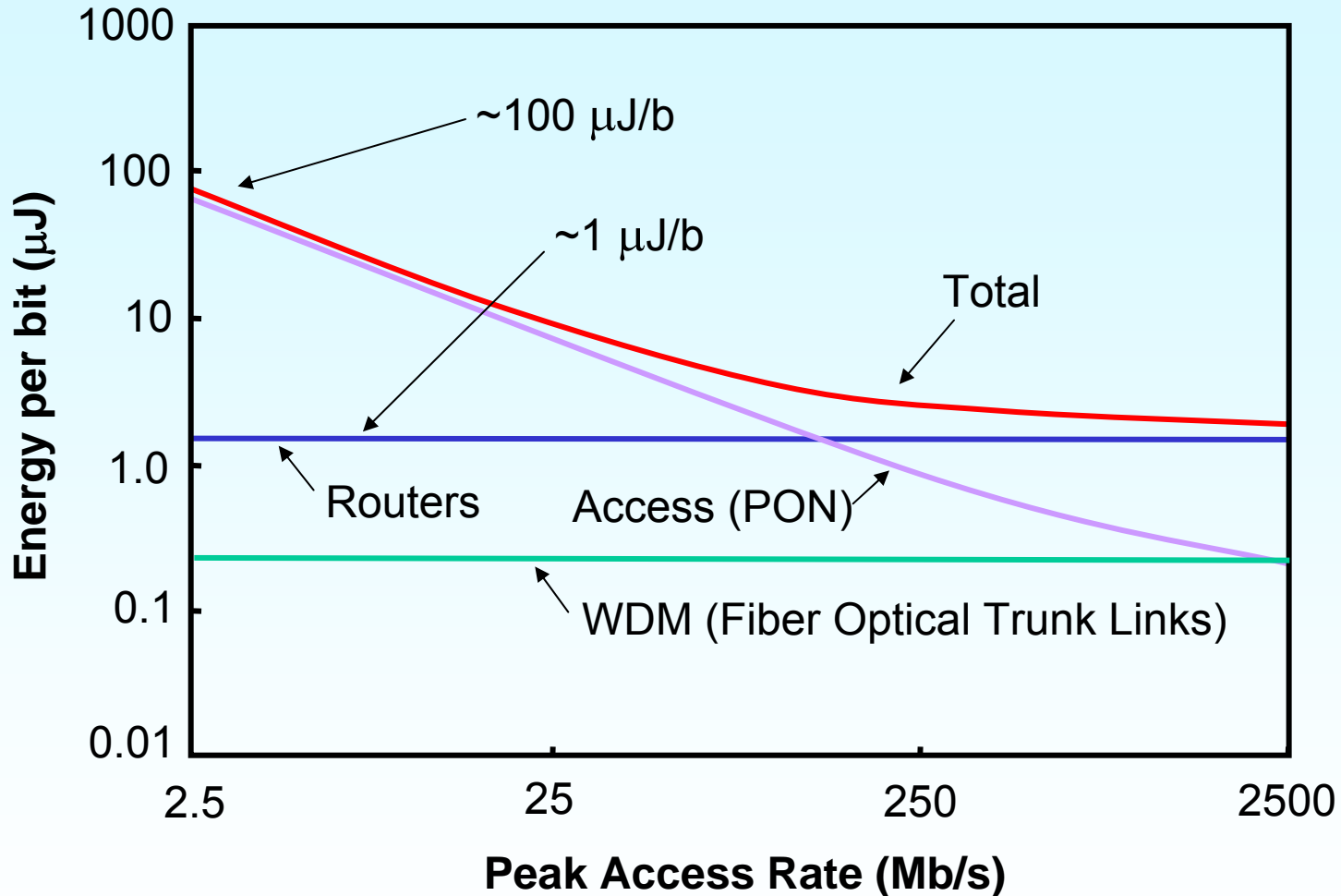

Energy per Bit in Network Devices

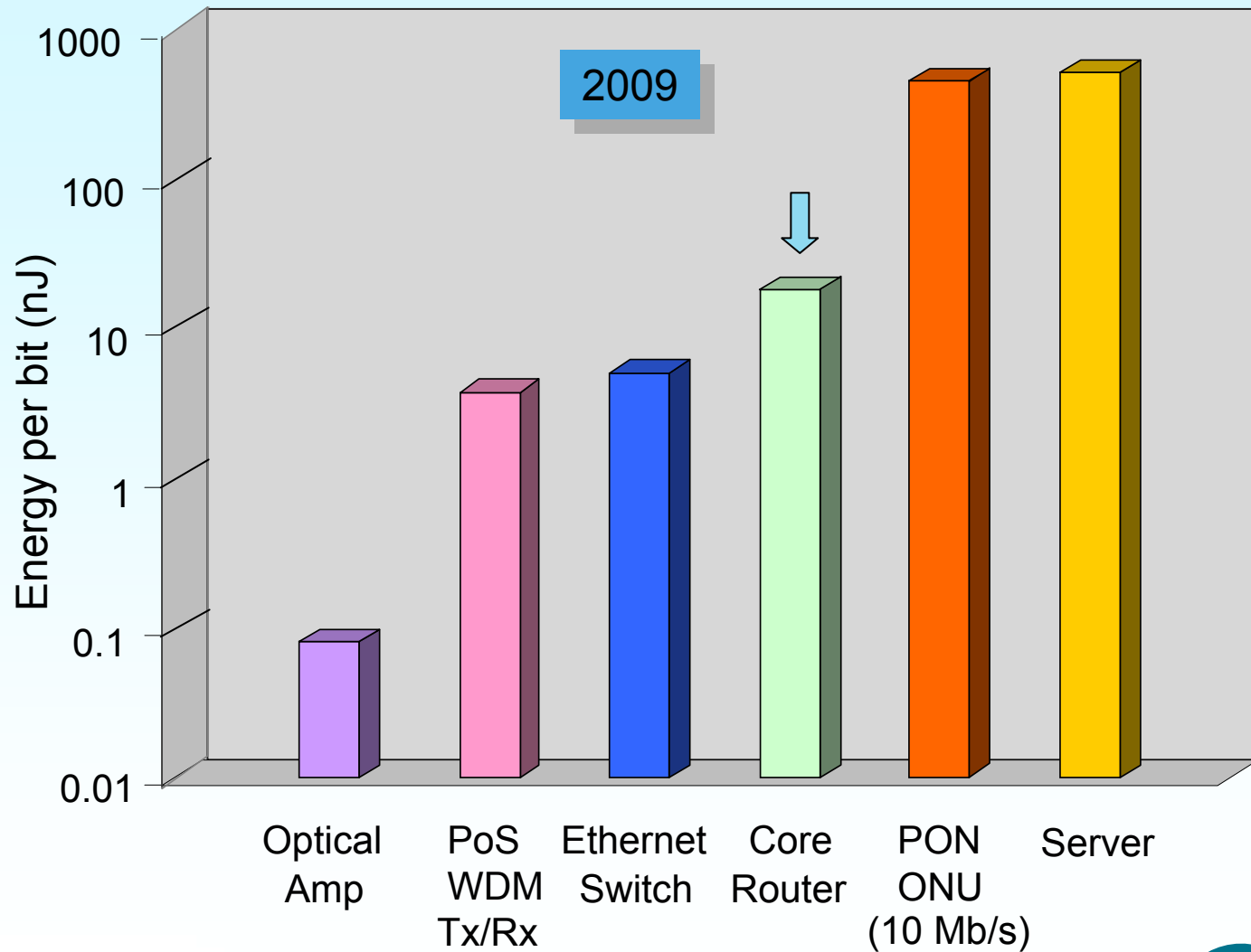

Router Capacity Growth

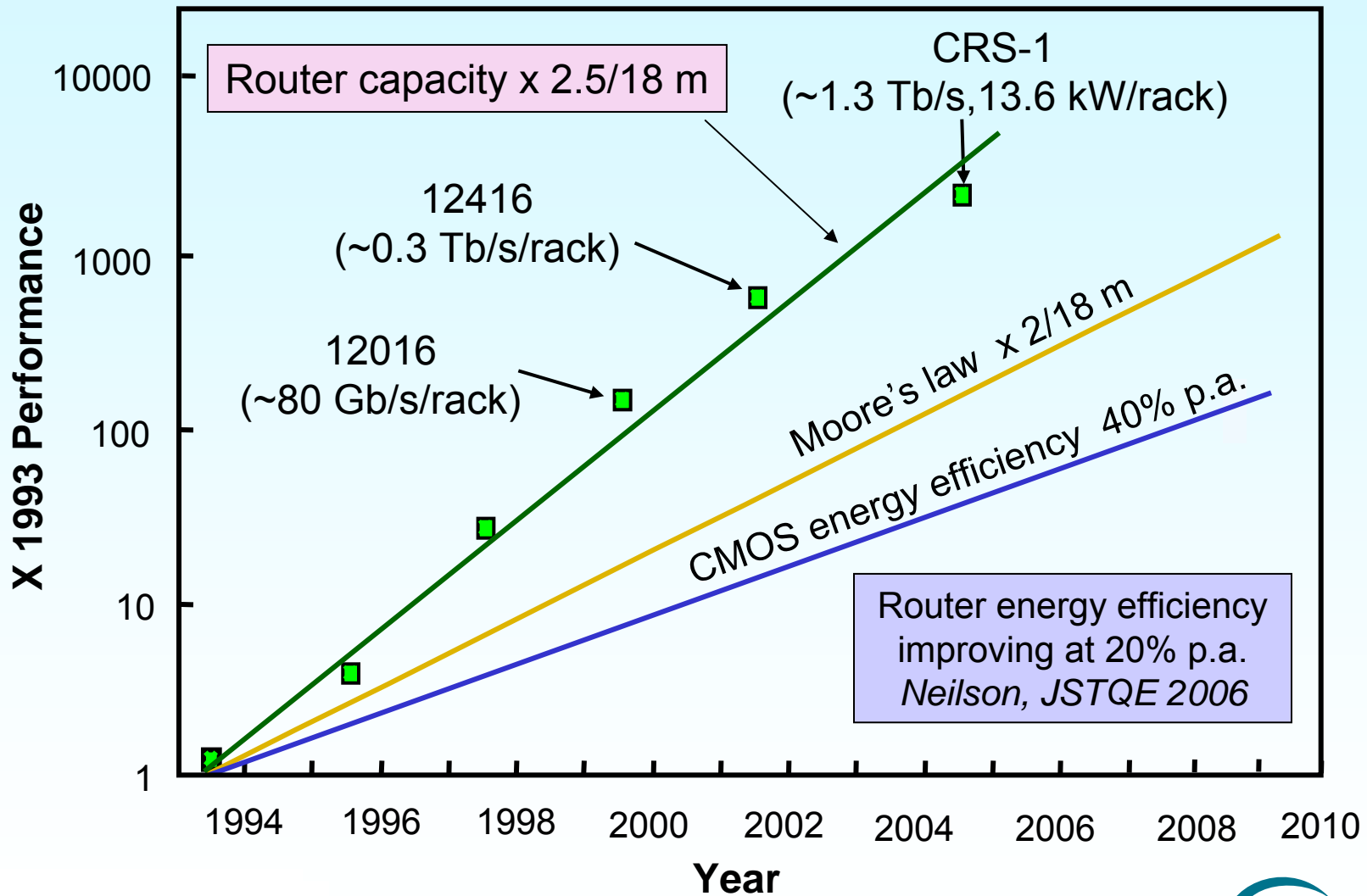

Based on G. Epps, CISCO, 2006



Energy in Electronic Integrated Circuits

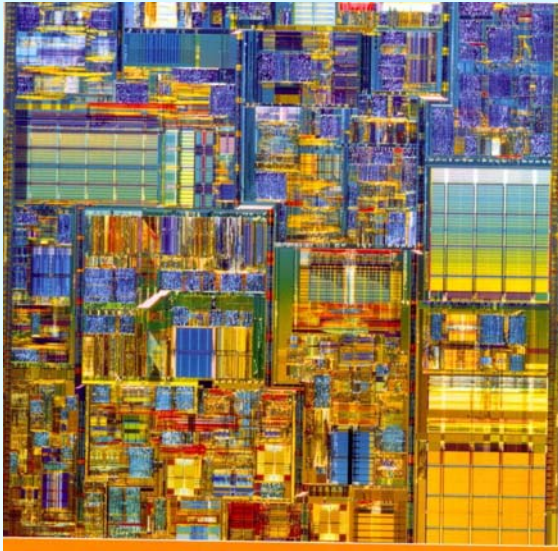

CMOS IC

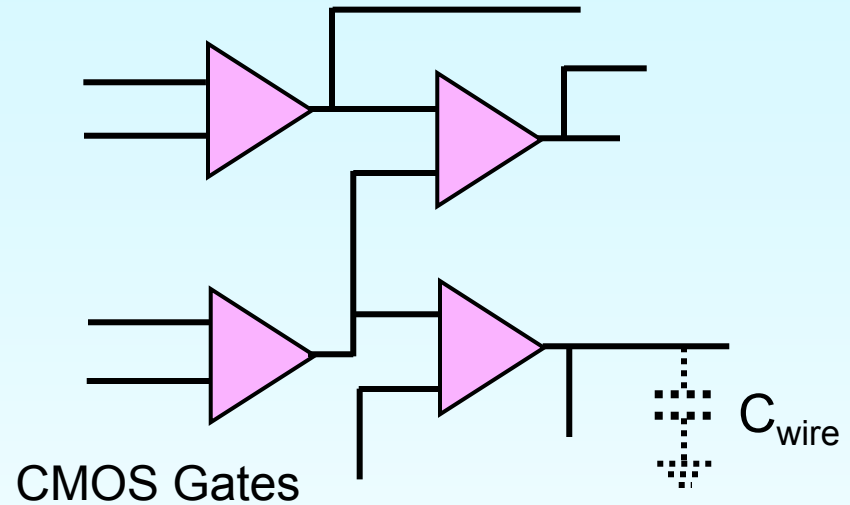

$$\text{Energy} = \sum E_{gate} + \frac{1}{2} \left[\sum C_{wire} \right] V^2$$

$$\text{Power} = \text{Energy} \times \text{Bit Rate}$$

Improvements in CMOS

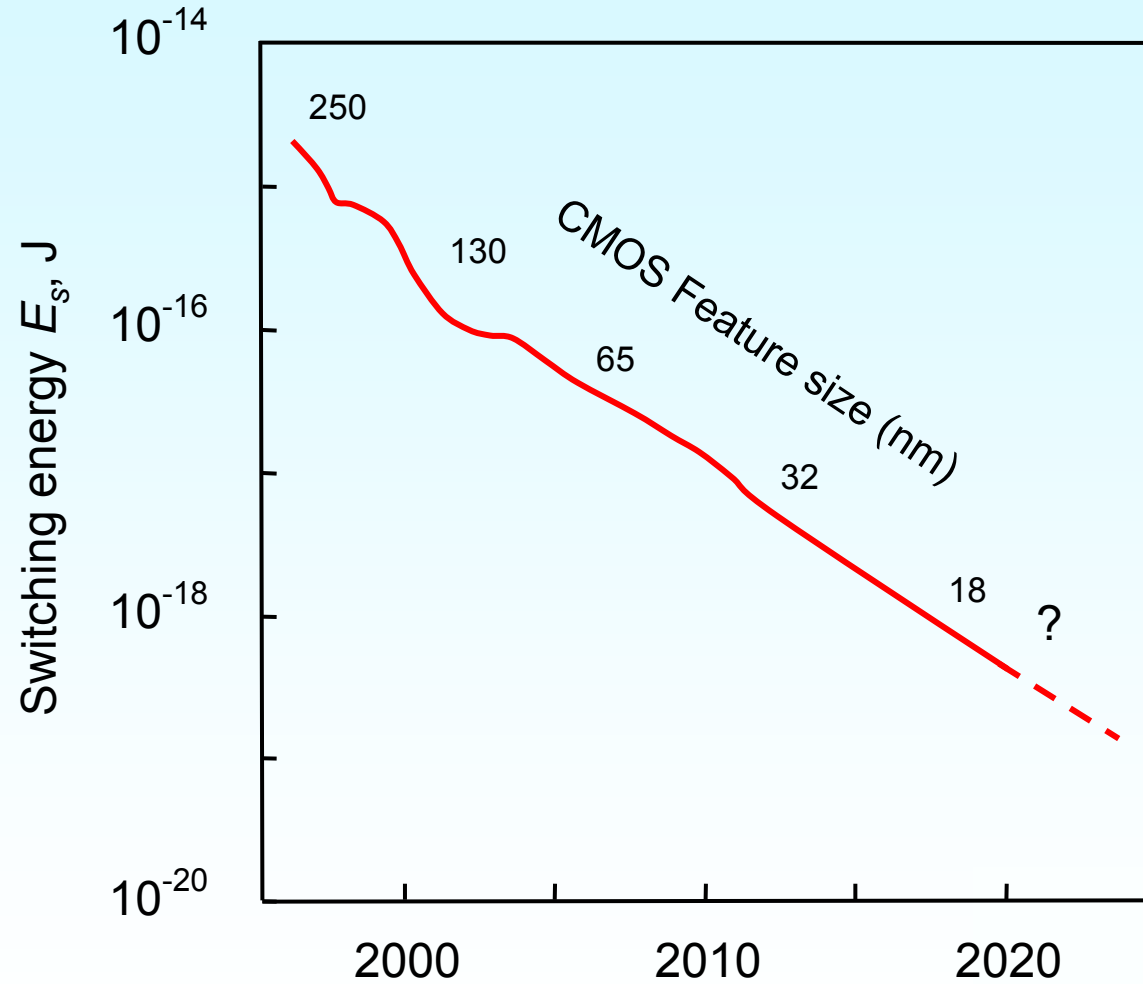

Effect of Efficiency Gains

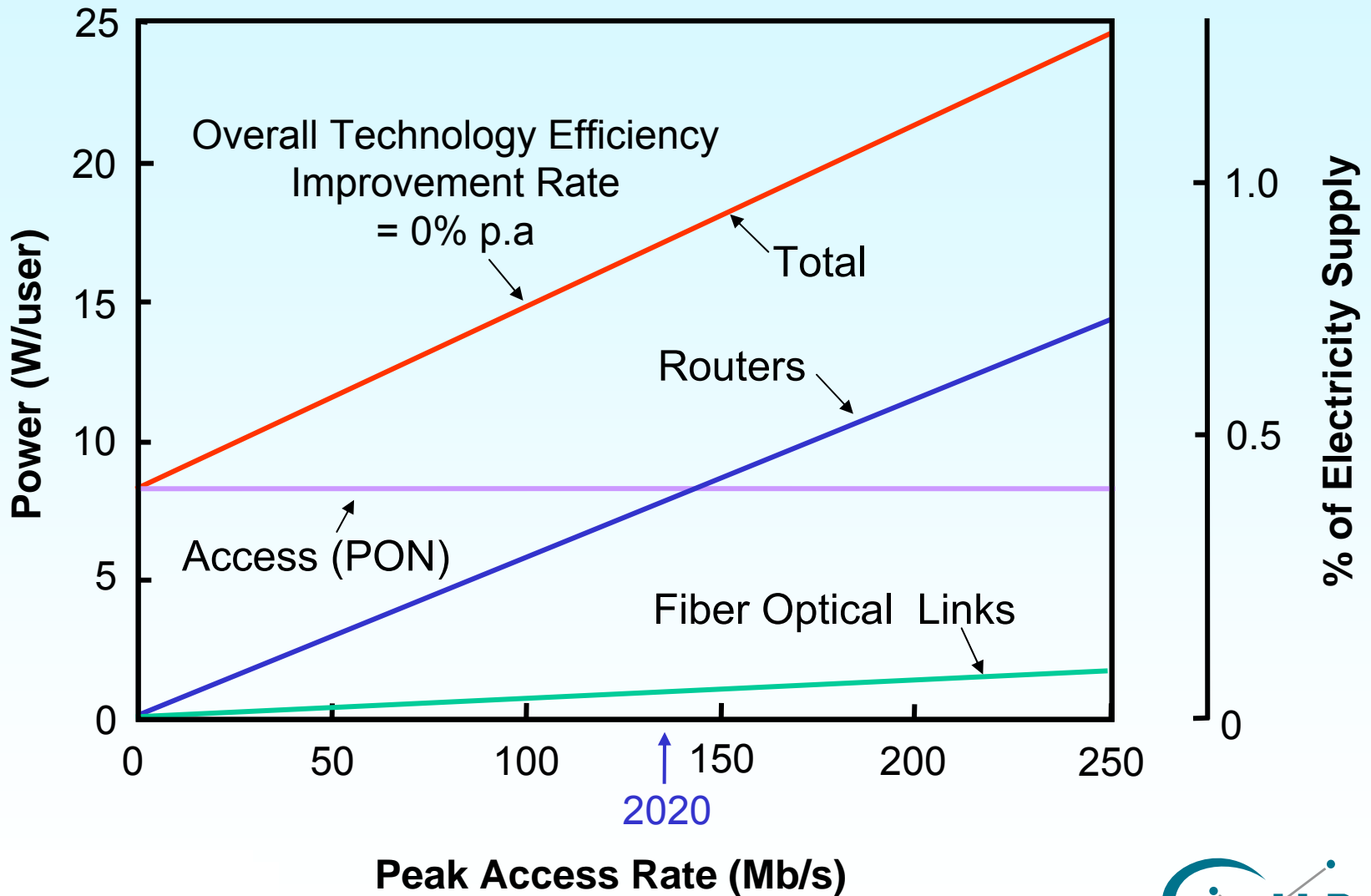

Effect of Efficiency Gains

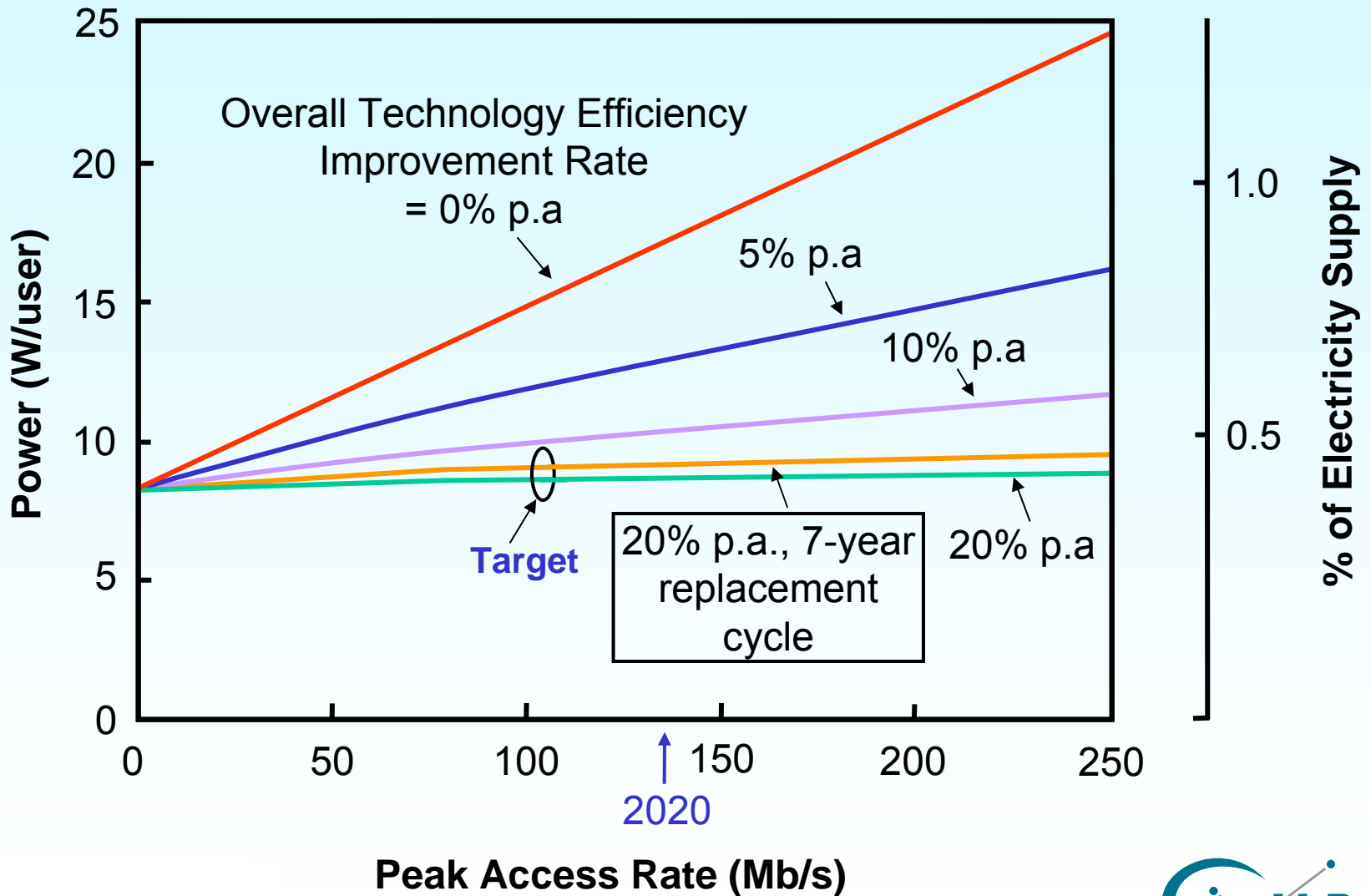

Towards Energy-Efficient Networks

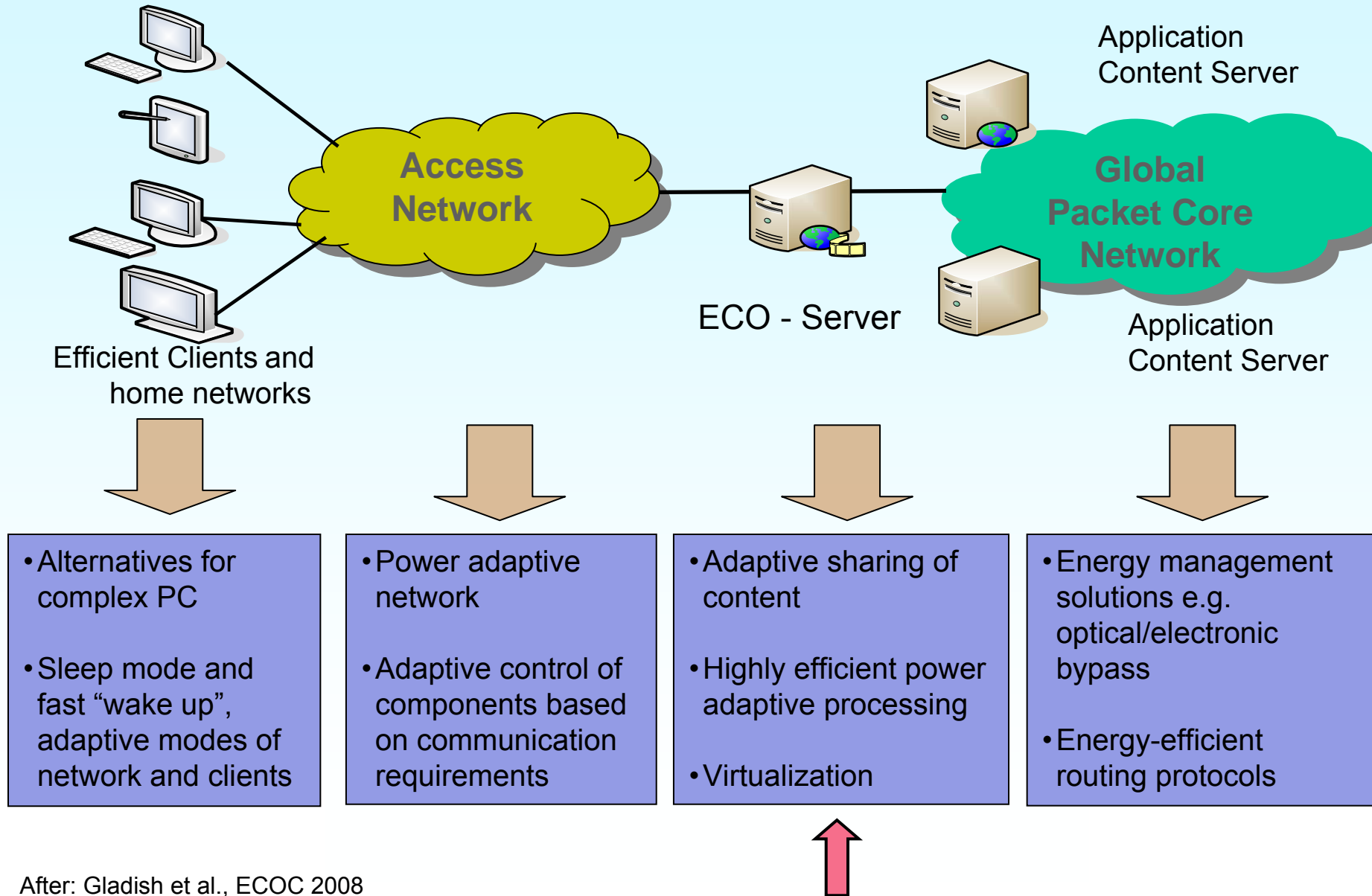

Cloud Computing

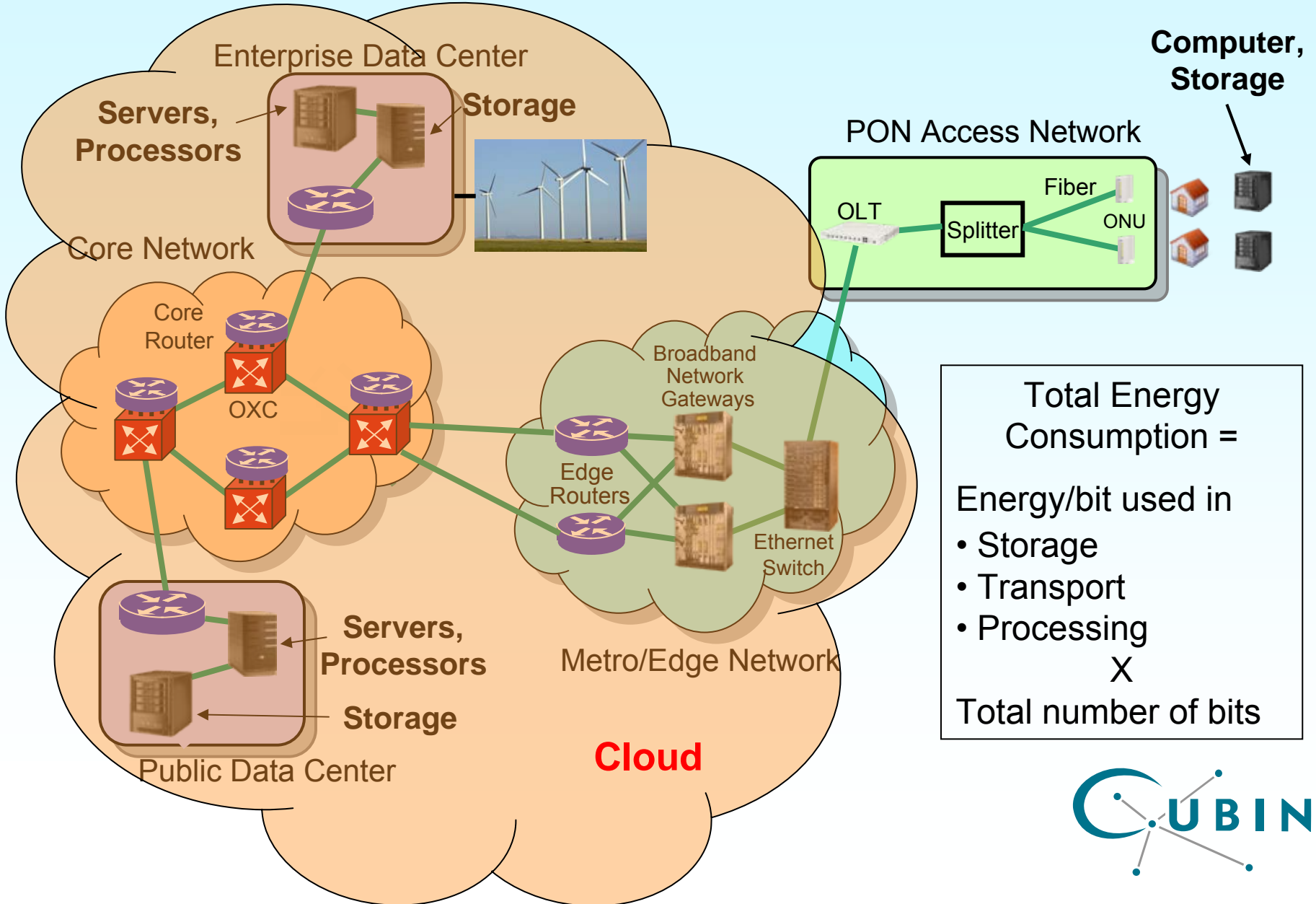

Low end Computer vs. Outsourcing to Cloud

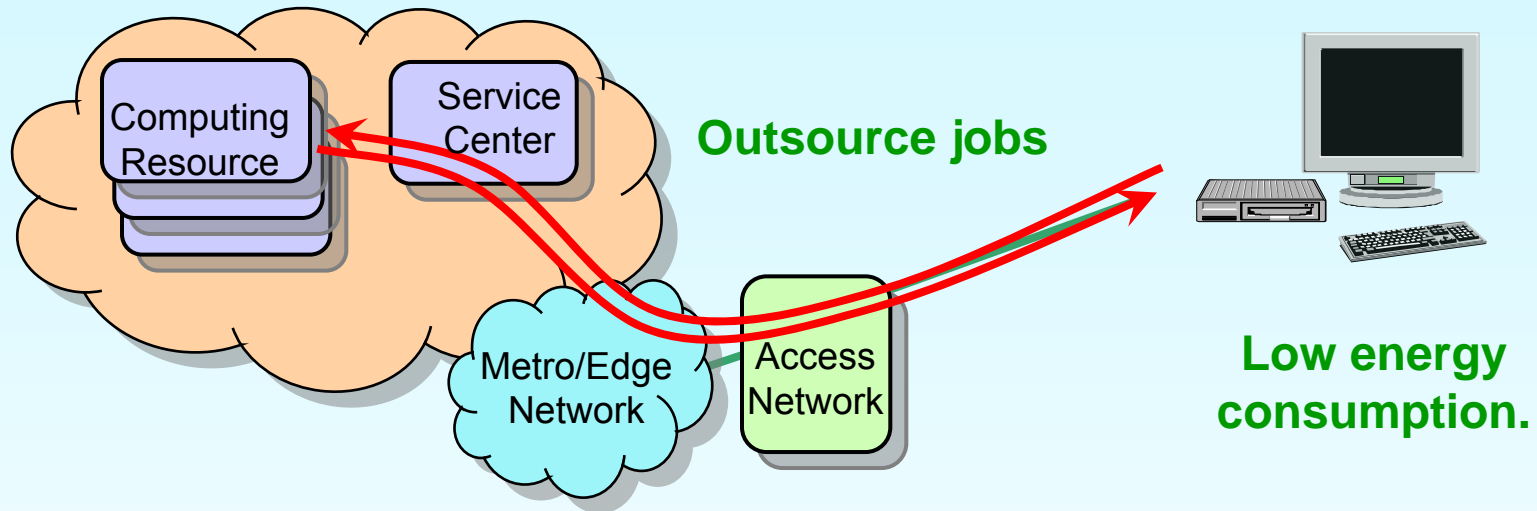

- OR -



High-end computer that can handle all of my jobs

But high energy consumption even for light jobs



Three Possible Scenarios

- **Software-as-a-Service**
 - Stored on user's computer with updates downloaded regularly
- **Service Bureau**
 - Most tasks done on lower end user machine, outsource the “big” jobs
- **Computing-as-a-Service**
 - Hosted and run on provider computer “farm” with data initially uploaded from user

Can cloud computing save energy ?



Service Bureau

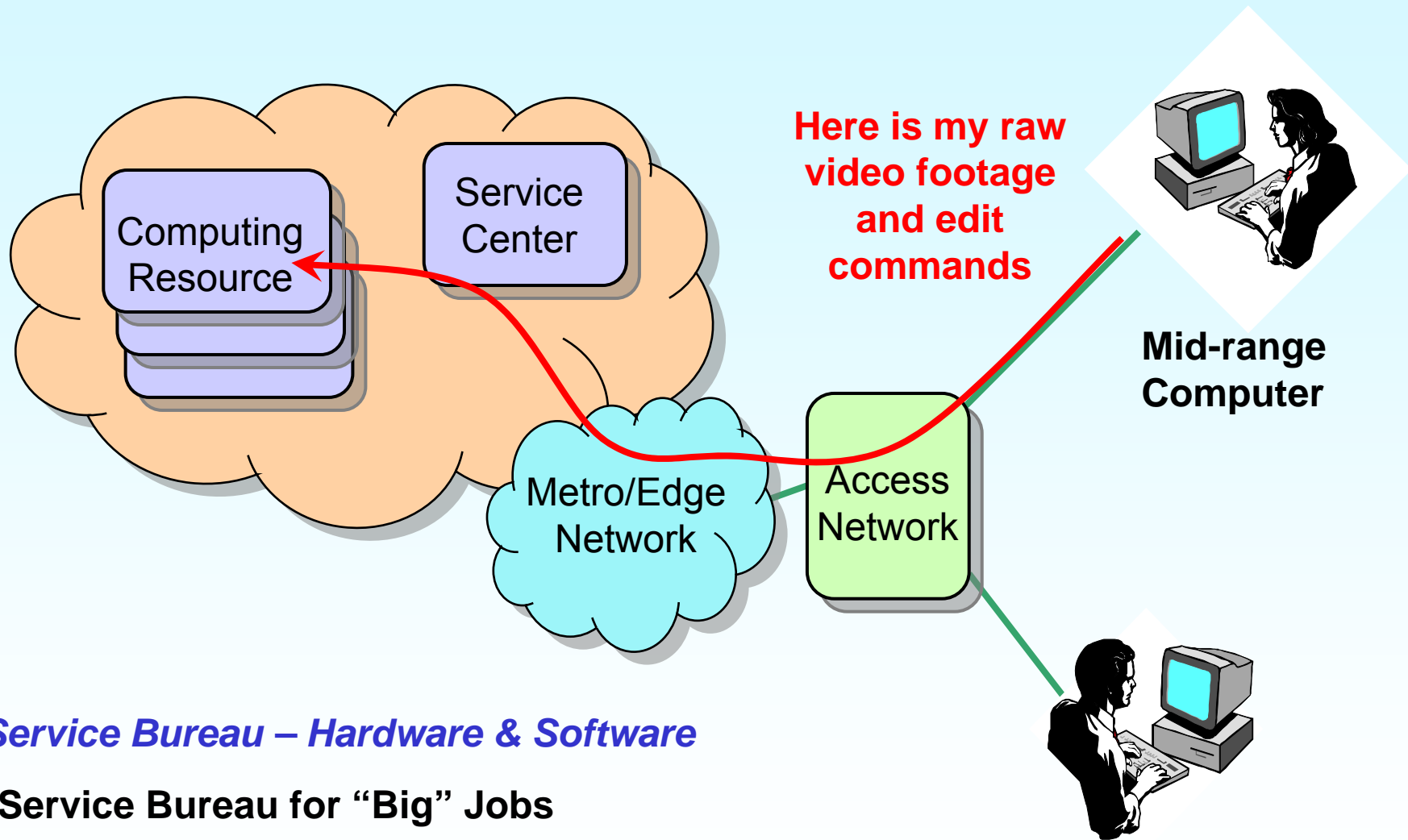

Service Bureau – Hardware & Software

- Service Bureau for “Big” Jobs

Service Bureau

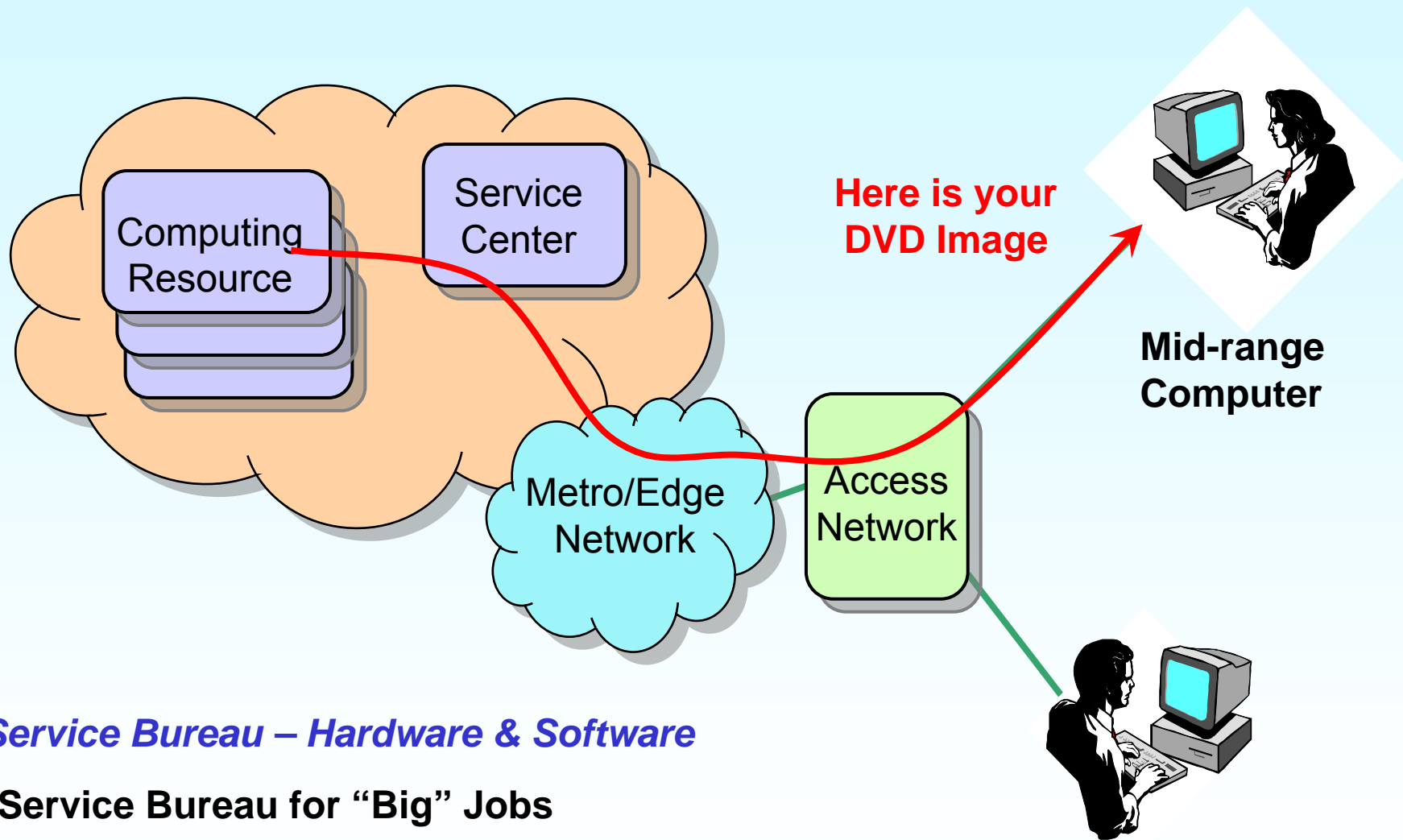

Service Bureau – Hardware & Software

- Service Bureau for “Big” Jobs

Service Bureau Example

Computer used for 20 hrs/week, plus some video encoding of ½ hour videos

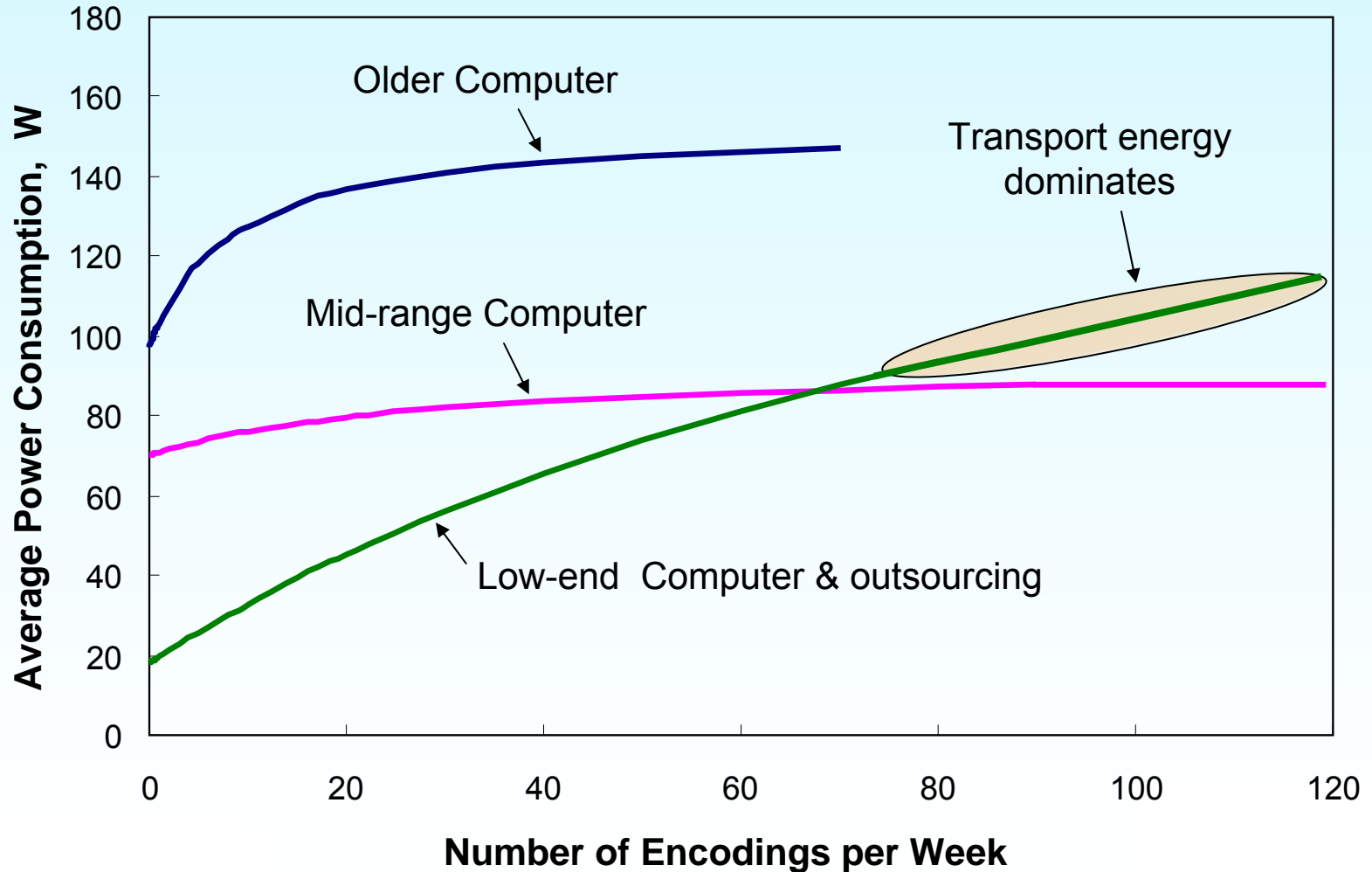

Data by Airmail vs. Data by the Internet

Data by Airmail:

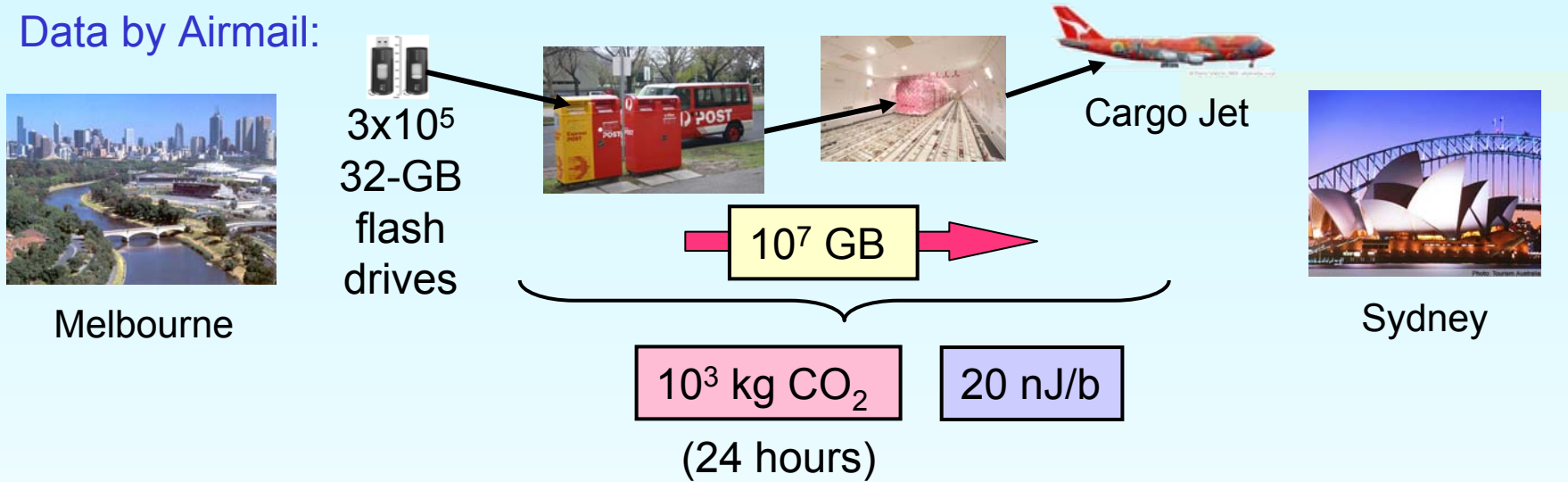

Data by Internet:

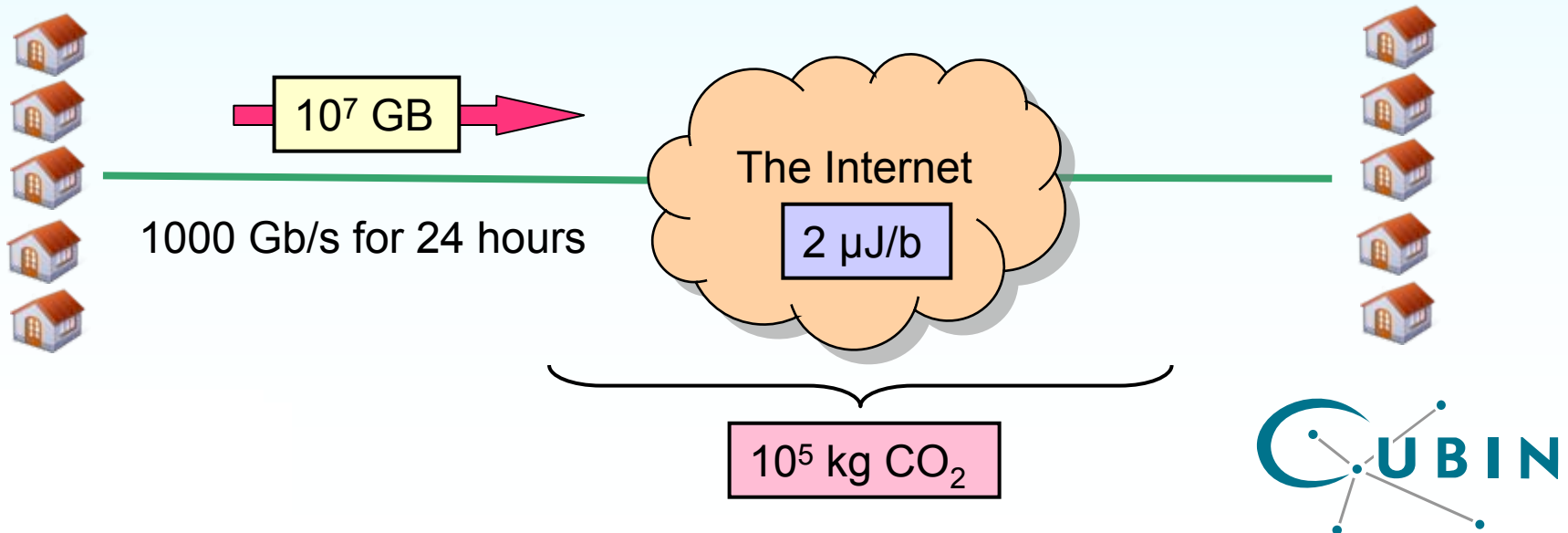

Energy Consumption per Bit

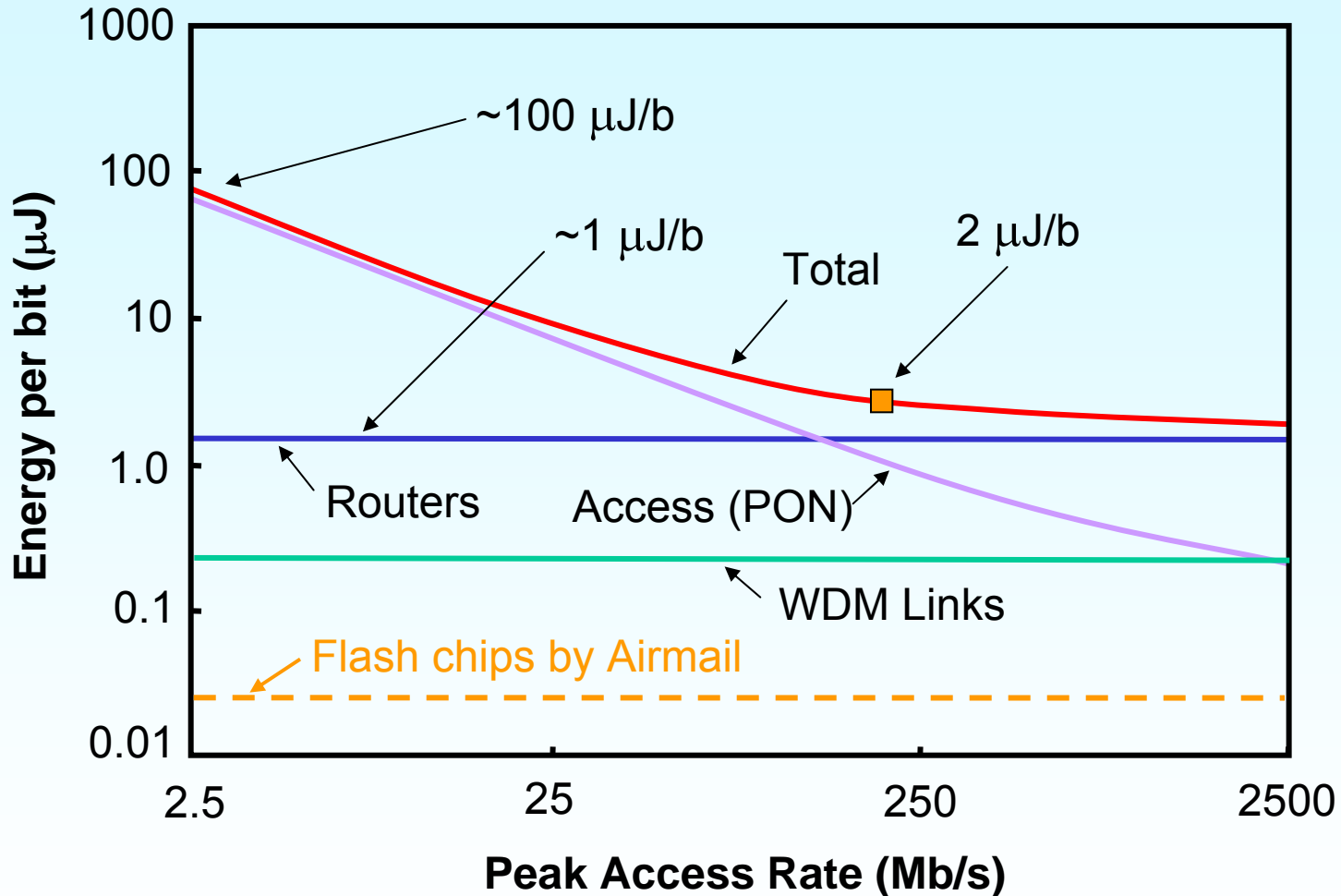

Using the Internet for Travel Replacement

Video Conferencing



Travel Replacement - Greenhouse Impact (CO₂)

Air Travel



Melbourne



~500 kg/person return

Business Meeting



Sydney

Video Conferencing



2 X 0.2 Gb/s for 8 hours
= 1 TB

~1 kg/person



Rod's Telecommute Calculator

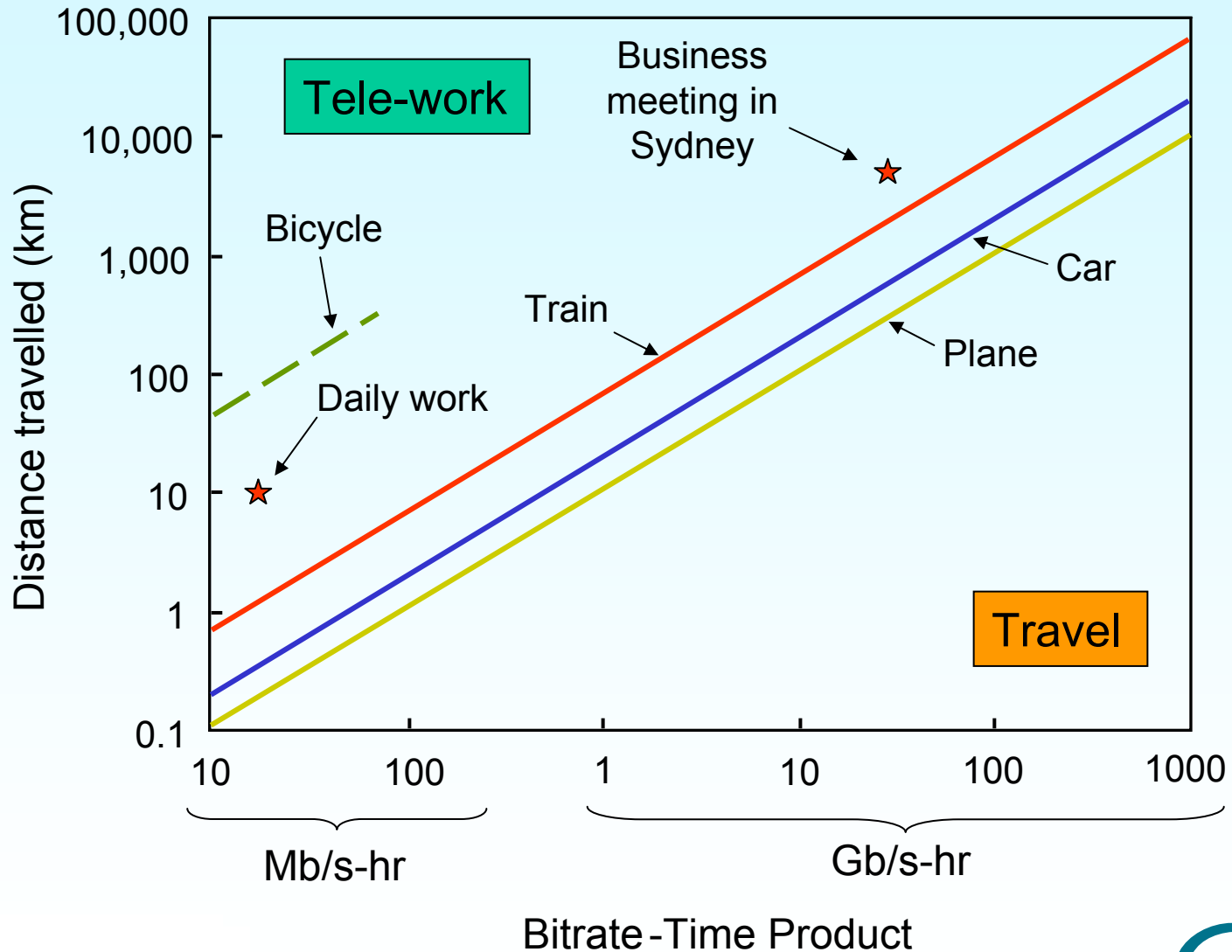

Summary – The Way Forward

- **Energy consumption of the Internet is small, but growing**
- **Internet energy consumption dominated by the access network**
 - **Energy-efficient user modems are a priority**
- **Core network energy consumption is relatively small**
 - **Improvements in Silicon technologies will be important**

