



TransLight/Pacific Wave

NSF-Award #0441119



Annual Report

03/01/2006-02/28/2007

Program Manager: Kevin L. Thompson
NSF/OCI Office of Cyber-Infrastructure

Principal Investigator

John Silvester
Professor of Electrical Engineering
University of Southern California
Los Angeles, CA 90089-2562
+1.213.740.9730
+1.213.716.8709 (mobile)
+1.213.740.4631 (fax)
jsilvest@usc.edu

Co-Principal Investigator

Ron Johnson
Vice-President for Information Technology
Vice Provost
Associate Professor
University of Washington
ronj@cac.washington.edu

1. Introduction

The primary objective of the Translight/PacificWave project (TLPW) is to build out the Pacific Wave international R&E exchange capability on the West Coast and to provide support for the international R&E links landing there. The project enables connectivity between US research and education networks and international links landing on the West Coast and provides technical and engineering support to configure the exchange connections to enable scientific collaborations that rely on advanced networking capabilities.

In addition to building out the exchange infrastructure, the project provides funding to help defray equipment, landing and operations costs for several international R&E links that land on the West Coast. Of particular note are two 10G circuits from Australia through Hawaii to Seattle and Los Angeles. The Australian Research Network (AARNet) paid up front one-time and ongoing costs for these links and TLPW covers the US land costs for the links (including backhaul to the PacificWave exchange points in Seattle and Los Angeles; network operations; monitoring of the links; and engineering and technical services for support of the links). In addition, in coordination with the University of Hawaii (that will be added as a formal sub-award in year 3), TLPW provides funding to land the trans-Pacific links in Hawaii. The Northern link lands in Oahu and is connected to the University of Hawaii network and the Southern link lands in the Big Island of Hawaii where there are plans to connect to the Observatory network that is managed by the University of Hawaii.

TLPW also provides engineering and operational support for many other International R&E links that connect to Asia, Australia and New Zealand, Canada, Central and South America

This project greatly enhances the ability of US scientists to collaborate with researchers in East Asia, Australia, New Zealand, North, Central, and South America (and beyond through other connected networks) and provides access to a diverse set of significant scientific resources throughout the region.

On October 24-25, 2006, NSF conducted a review of the IRNC projects. The comments from that review provide an excellent overview of the project – we reproduce them here.

Translight/Pacific Wave does a good job at operating an open global exchange at Layer 2 and providing GOLE interoperability. The program helped create “critical mass” for PacWave exchange to become an integral piece of US and international R&E networking fabric. The networking solution is interesting in that the concept of a “distributed exchange,” i.e., the provision of wide-area Ethernet switched service in the form of point-to-point or shared VLANs is new. The new Translight link (a donated Cisco research wave) offers opportunities for GLORIAD and other domestic R&E networks to use an intra-US link to interconnect nodes on the West Coast to Chicago. The active usage of this project’s resources by a number of high-speed applications is impressive.

Translight/Pacific Wave has created a layer 2 distributed peering point for interconnecting international networks. This infrastructure does not use layer 3 routing, but only a distributed system of Ethernet switches to provide VLANs, both shared and dedicated, to customers. This peering fabric, stretching between Los Angeles and Seattle, draws the international network providers to peer with each other through this fabric bringing access to these networks to the US. Pacific wave supports both Ipv4 and Ipv6 standard and jumbo frames throughout the distributed peering point and is AUP-free. Translight also interconnects Australia through Hawaii to North America. When the southern AARnet connection is completed, this will provide an extension of the network to Hawaii and Australia. They have also done a great job in leveraging IRNC investments and have established good working relationship and coordination with a wide range of partners. TransLight/PacificWave has worked very closely with CENIC, the University of Hawaii, and AARnet in order to build out its infrastructure across the pacific.

This project deals primarily with two objectives; facilitating international R&E connections in the Western US (including Hawaii) and providing local connectivity between the two landing points of the Australian AARnet transpacific cables and the Pacific Wave exchange. Operating in this space, it is unclear exactly what can be measured overall.

An important component is the backhaul link service provided by this project to AARnet (Australian R&E network). Through this, access to the important telescopes on the mountains of Hawaii is made possible for many scientists in the US (e.g., the eVLBI project). Further this project provides a unique service by connecting CSIRO scientists from Australia to US resources and vice versa. Besides iGRID05 and SC05 demonstrations, the PI showed a number of usage examples, the Huygens Titan probe data transfer to Australia, a tele-microscopy demo between University of Hawaii and UCSD, a Honolulu 270Mbps interactive HD video conferencing with Australia and Seattle. an uncompressed HDTV lecture between Seattle and JGN meeting in Tokyo, the NASA Infrared Telescope Facility (IRTF), etc.

2. Project Structure

The project is based at the University of Southern California where it provides partial support for the Principal Investigator, a part-time project support person, and some access to technical engineering expertise.

There are several sub-awards. In years 1 and 2 of the project there are two sub-awards: the Corporation for Educational Network Initiatives in California (CENIC) and the Pacific Northwest Gigapop (PNWGP). These two non-profit organizations provide networking capability to the Research and Education communities in the Western part of the United States and they jointly operate the exchange facility called Pacific Wave. The project provides funding to CENIC and PNWGP to operate the exchange in support of the National and International Research and Education Networks (RENs) that

interconnect through its facilities. Pacific Wave operates a “distributed exchange” through which any two participating networks can peer directly, no matter which of the PW points of presence (POP) that they connect to. This provides great flexibility and economy to the participating networks and greatly facilitates network interconnect.

The other key partners at this stage of the project are: the Australian Academic Research Network (AARNet) and the University of Hawaii. AARNet operates a National REN (NREN) for Australia and has contracted with Southern Cross for two trans-pacific 10 Gigabit links. TLPW partners with AARNet to land these links in the US and backhaul them to Pacific Wave exchange facilities in Seattle and Los Angeles. In addition, TLPW provides the end-end grooming and routing equipment for the US side of the links. CENIC and PNWG provide engineering, operations and management of the US side of these links and provide for peering through the Pacific Wave distributed exchange.

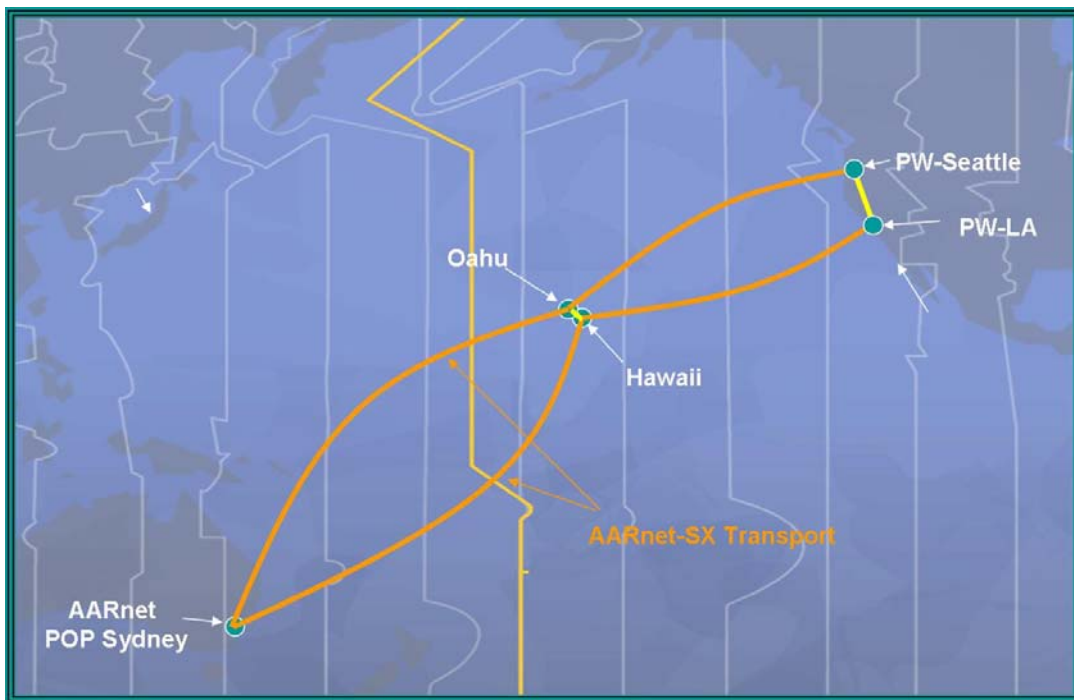

Figure 1: Overview of the AARNet SX-Transport Transpacific Links

The links pass through Hawaii (see Fig. 1), the Northern route passing through Oahu, and the Southern link passing through the Big Island (Hawaii). The TLPW project, in conjunction with the University of Hawaii, is acquiring equipment to allow connection of these links to the University of Hawaii and also to the important Big Island Observatory Network that provides connectivity to the various observatories located on Mauna Kea on the Big Island. The University of Hawaii has responsibility for managing equipment and backhaul to support the connectivity of the Northern link that lands in Oahu, HI. Currently the connectivity from the Northern link to UH is over a 1-G connection – there are plans to upgrade this link in year 3. We were originally planning to add UH as a sub-contractor to the project in year 2, with a particular objective to build out backhaul and enhance connectivity to the observatories on the Big Island, but this has been moved

forward to year 3 since lighting of the SX-Transport South was not completed in year 2 (due to equipment selection delays in Australia).

The project provides a fixed amount of annual funding to CENIC and PNWGP for engineering, support, and maintenance of the facilities that they provide and operate. Equipment to support the connections is acquired by CENIC and PNWGP (and later by the University of Hawaii) to support these links. These equipment purchases are explicitly approved by the USC P.I. and are reimbursed as additional cost items to the sub-contracts. Thus the equipment money resides in the USC account until spent, providing greater flexibility and oversight in allocation of project resources.

PNWGP and CENIC are responsible for providing NOC (Network Operations Center) services for the links and for working with other NOCs in problem resolution. In addition, PNWGP and CENIC provide measurement infrastructure that can be utilized by the IRNC measurement projects, although the statistics that are available are limited due to the nature of the exchange operation and restrictions imposed by the Exchange participation agreements. PacificWave works with its participant networks to provide access to their measurement facilities and statistics when acceptable.

3. Accomplishments and Activities in Year 2

3.1 Summary of Operations and Management

Regular (biweekly) teleconferences were held with all TLPW participants (CENIC, PNWGP, UH, AARNet), allowing for problem resolution and network planning.

Pacific Wave Engineers from CENIC and Pacific Northwest Gigapop hold regular Engineering calls to discuss issues and operations. In addition, technical postings are cross-posted to distributions lists in AARNet, CENIC, PNWGP and UH.

PacificWave management (representatives from CENIC, PNWGP, USC, and the University of Washington) hold regular meeting 2-3 times per year for futures planning and general oversight of the Exchange.

3.2 Accomplishments against Project Objectives

In year two of the project, the following was accomplished.

1. Continued operation of the Pacific Wave distributed Exchange facility to interconnect layer 3 networks over a switched layer 2 VLAN infrastructure.

As of March 2007, there were three points of presence for Pacific Wave: Los Angeles, Seattle, and Sunnyvale, with Los Angeles having three locations (at different carrier facilities), where a network can connect (see Figure 3.). In Sunnyvale, the exchange also provides a connection to PAIX.

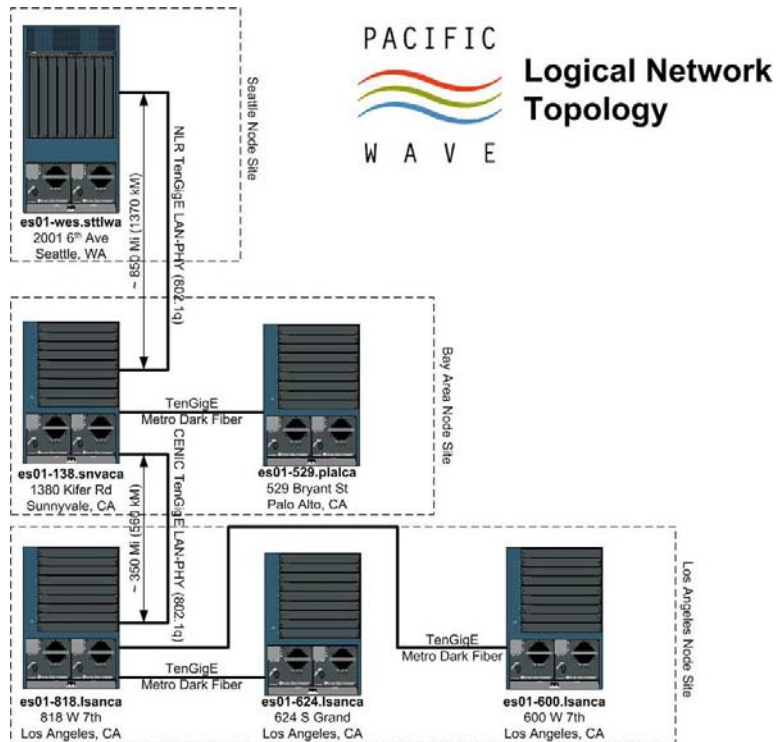

Figure 2. PacificWave Exchange Topology.

Connectivity between the sites is provided over 10Gbs links provided by CENIC’s CalREN and the National LambdaRail (NLR).

A summary of new participants and/or upgrades or reconfigurations completed in year 2 is shown below.

- 2006.01 - NLR joins PW-Seattle at 10 GigE
- 2006.02 - MS Corp upgraded to 10 GigE Seattle
- 2006.04 - Palo Alto Exchange point site Operational
- 2006.05 - KreoNet2/KOREN upgrades port to 10 GigE at PW-Seattle
- 2006.06 - Translight/Pacific Wave and Translight/Starlight connect via 10 GigE connection donated by Cisco
- 2006.08 - NREN joins PW-Sunnyvale at 10 GigE
- 2006.08 - KAREN/REANNZ joins PW-Seattle at one GigE
- 2006.10 - CLARA joins PW-Los Angeles at one GigE
- 2006.10 - CUDI joins PW-Los Angeles at one GigE
- 2006.10 - L-ROOT (ICANN) joins PW-Los Angeles at one GigE
- 2006.12 - NLR adds second port at PW-Los Angeles at 10 GigE

A summary of the current (as of Jan 2007) R&E participants in PacificWave is shown in the diagram below.

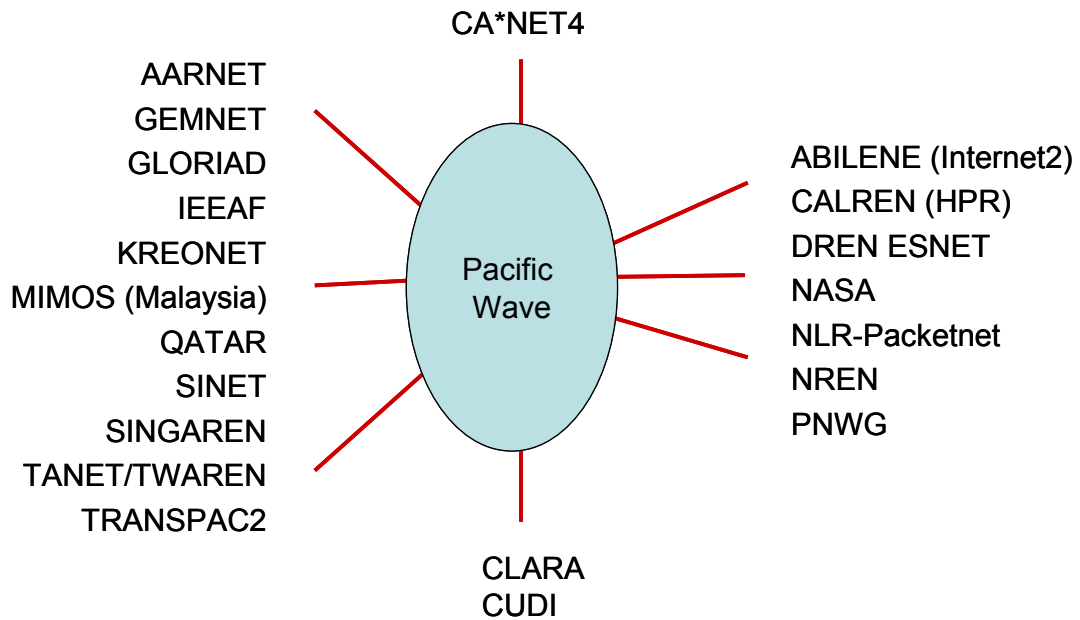

Figure 3. Pacific Wave Layer 3 Research and Education Network Participants (January 2007)

In addition, we continue to see growth in interest and demand for “lightpath” interconnect. Some of the networks and projects already using these services or who have indicated their plans to use such services are shown below.

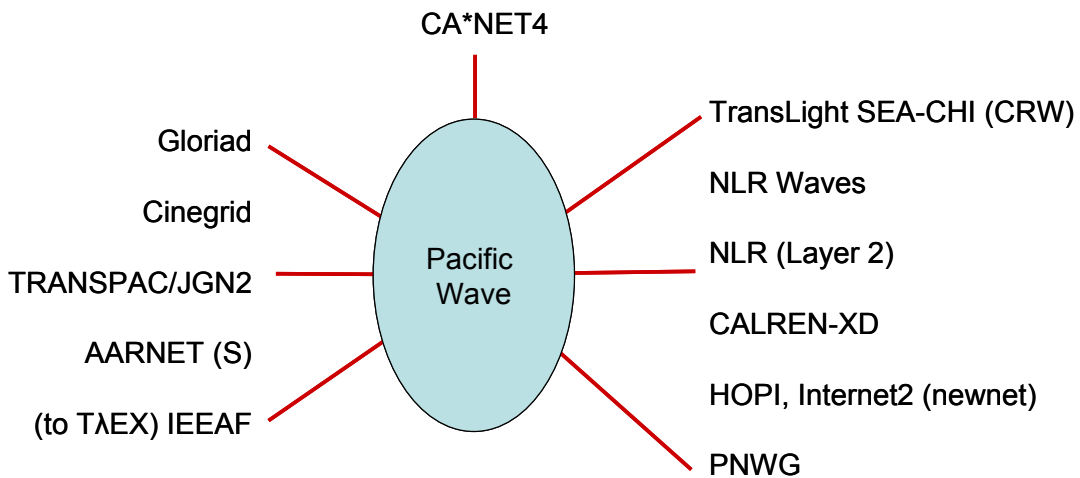

Figure 4. Pacific Wave Layer 2 Participants Active and Planned (January 2007)

2. Expanded Facilities and Capabilities of PacificWave Exchange.

In order to support the increased demand for layer 1 and layer 2 interconnect, PacificWave expanded its infrastructure. With the deployment of the CISCO 15454 in Los Angeles (which will be used to terminate the AARNet S. link) it became possible to provision GE circuits between Los Angeles and Seattle (to a Nortel HDxC box provided by Canarie). (This also allowed for some interoperability tests between Cisco and Nortel equipment). An additional 10G wave over CalREN and NLR from Los Angeles to Seattle was acquired and used to support this connection. This configuration has been installed and tested in anticipation of the AARNet Southern link becoming operational. It has also been used by some projects on a short term experimental basis. The intent is to make this CISCO 15454 the Exchange Multiplexer/Switch for Layer 1 and Layer 2 interconnects in Los Angeles and the Nortel box to provide a similar function in Seattle. While this is adequate for a small number of interconnects it may need to be upgraded as demand grows (and in particular if demand for dynamic circuits as anticipated in the Internet2 new network develops).

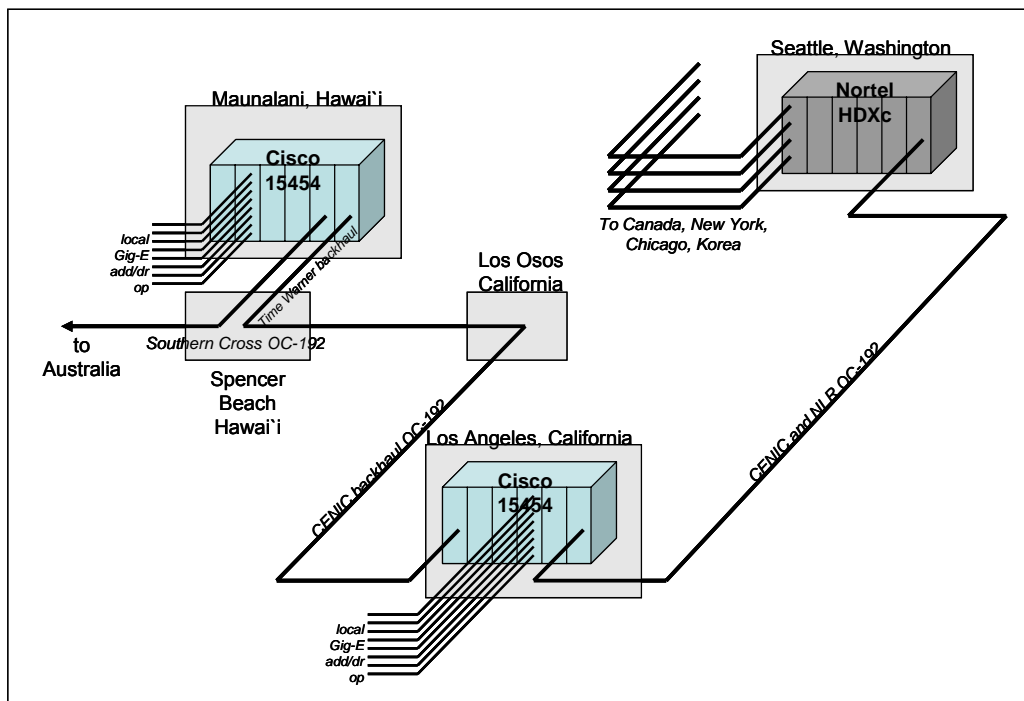

Figure 5. Detail of Lightpath/Circuit Capability in Hawaii, Los Angeles, and Seattle

In addition to the Sunnyvale PoP that came into operation in early 2006, the Exchange was extended to include presence at PAIX in Palo Alto.

A proposal was made to CISCO systems for the provisioning of a 10G “Research Wave” over the NLR infrastructure from Seattle to Starlight in Chicago to allow extension of the distributed exchange concept all the way to Chicago. This has allowed for some experimentation with direct peering between participants in PacificWave and Starlight over an extended VLAN infrastructure. This wave was made available as a donation from CISCO for one year and is renewable.

3. Continued use and support of the SX-Transport-North link from Sydney through Oahu to Seattle

The SX-Transport North was in operation throughout year 2 of the project.

4. Develop capability for SX-Transport South

The backhaul of AARNet SX-Transport(S) from Los Osos (CA) to Los Angeles over CENIC optical infrastructure was completed and tested.

In addition, the ETE equipment (CISCO 15454-MSP) in Hawaii and Los Angeles were installed and tested. Once similar equipment is in place in Sydney this will complete the SX-Transport South link and will provide for lightpath (layer 2) (8 x 1GE connections) from Australia to Hawaii and the US Mainland and from Hawaii to the US Mainland. (The missing link is the equipment in Sydney which is awaiting delivery — with the end of year freeze-outs it is expected that this will be installed and tested in March/April 2007.)

5. Build PW-Extension to CUDI and REDClara

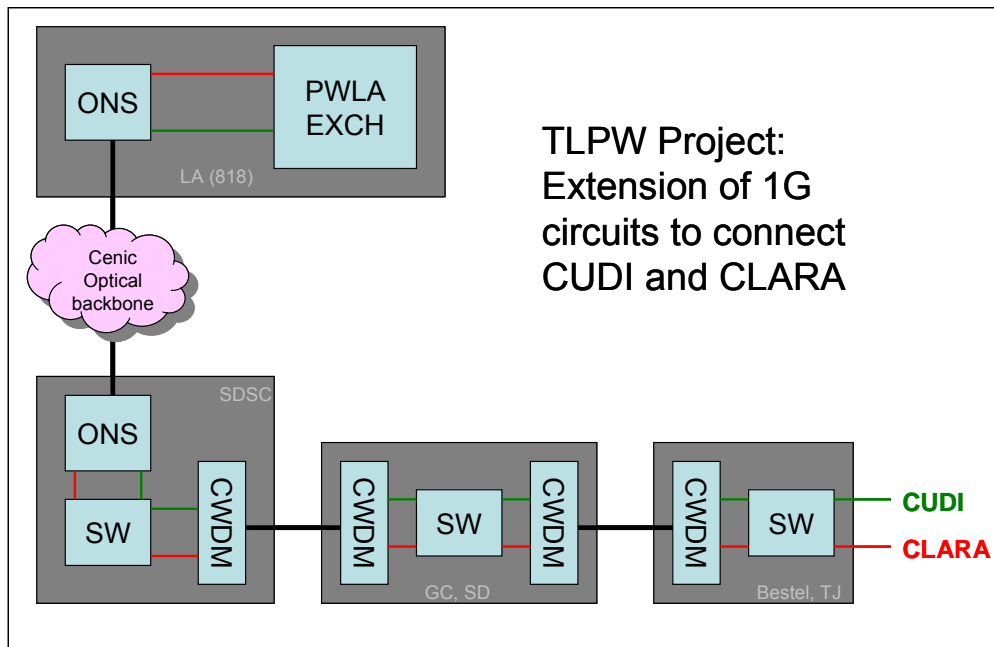

Figure 6. Backhaul of 1GE circuits form CUDI and CLARA to PW-LA

CUDI and CLARA share a PoP in Tijuana, Mexico. An opportunity existed to connect them to the PW Exchange in LA. Working in partnership with the WHREN/LILA IRNC Project, a fiber lease was arranged from Tijuana to San Diego and switches were installed in Tijuana and San Diego to enable two 1GE circuits – one for CUDI and one for CLARA - to be brought from Tijuana to San Diego and then over the CalREN infrastructure from San Diego to Los Angeles and on to Pacific Wave in Los Angeles.

This allowed these Latin American Networks to peer with US and other R&E networks in Pacific Wave directly (rather than by tunneling over CalREN).

6. Started planning for Application Oriented Workshops

A) We entered into discussions with the organizers of GRIDASIA to develop a track within the conference to focus on Science and Engineering Applications that can make good use of high bandwidth International connectivity and the type of services that PacificWave provides. The objective is to enhance collaboration by discussing these activities at a GRID meeting in Asia. This meeting will be during year 3 of the project.

B) We also entered into discussion with John O’Callaghan, director of APAC (Australian Partnership for Advanced Computing) to develop a 2 day workshop to run in conjunction with the upcoming APAC meeting in Perth in 2007. The plan is to identify key research areas (that would benefit from enhanced connectivity and cyber-infrastructure), identify leading Australian Researchers in these areas, have them identify and invite US current or potential collaborators, support the travel of the US contingent (5-6 scientists) to attend and participate in the workshop. This workshop will take place in year three of the project. A Steering Committee was established and planning will continue into year 3. Members of the steering committee are: John Silvester, Jacqueline Brown, George McLaughlin, Chris Hancock, John O’Callaghan, Robin Stanton, Lindsay Hood, Maxine Brown, Dane Skow.

C) We also entered into discussion with KAREN (Kiwi Advanced Research and Education Network, New Zealand) to participate in their upcoming national meeting (the first) by supporting some leading cyber-evangelists (who are also leading scientists) to help build the case for advanced networking in New Zealand and to help identify potential US-New Zealand collaborations that could be enabled by the new infrastructure. This meeting will be held in year 3 of the project.

3.3 Statistics and Use

The charts below show the total traffic passing through the PacificWave exchange for the 1st, 2nd, 3rd, and 4th quarters of 2006. We see steady growth in demand and can identify some of the peaks as being associated with known experiments, land speed record attempts or Supercomputing06.)

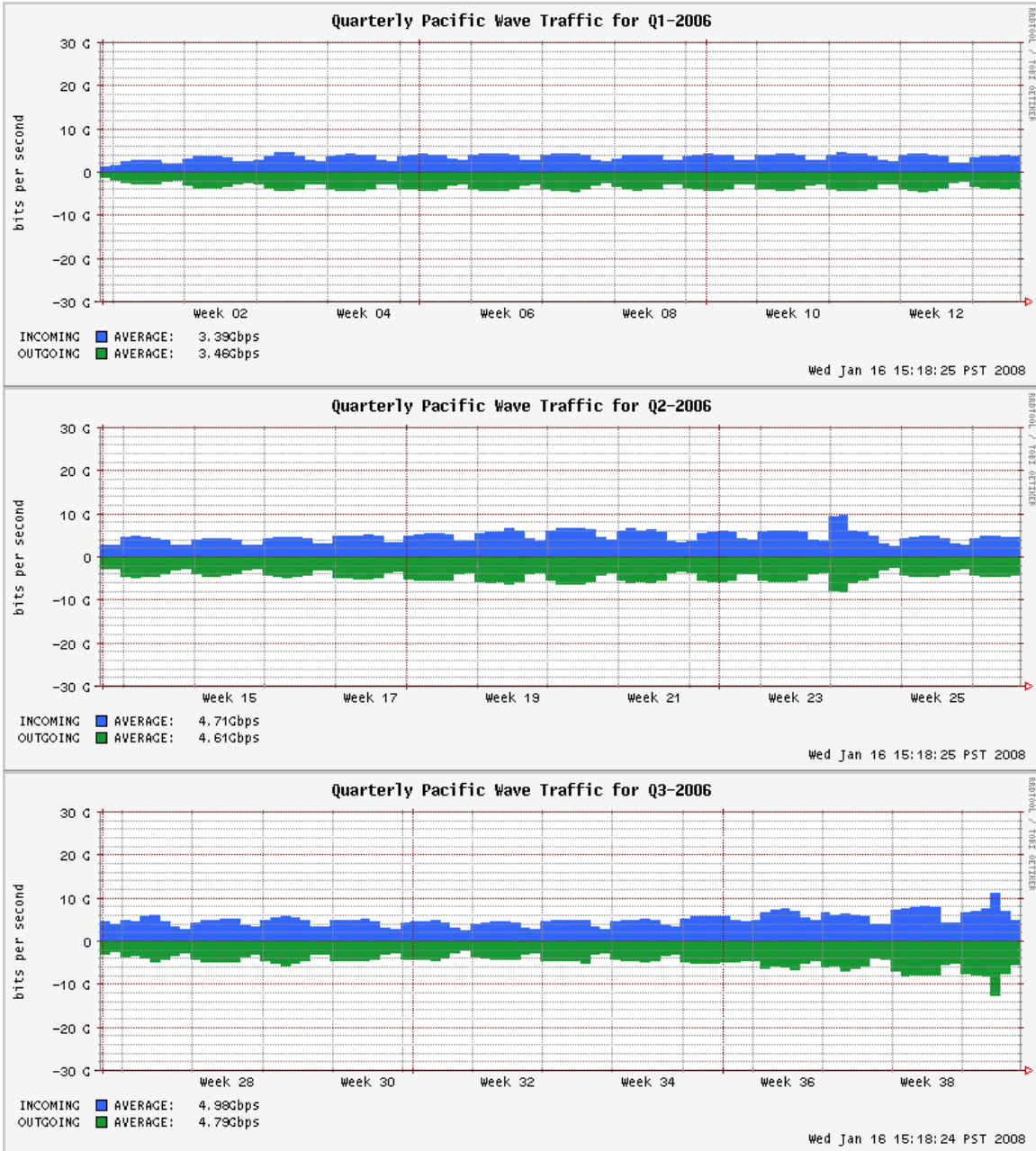

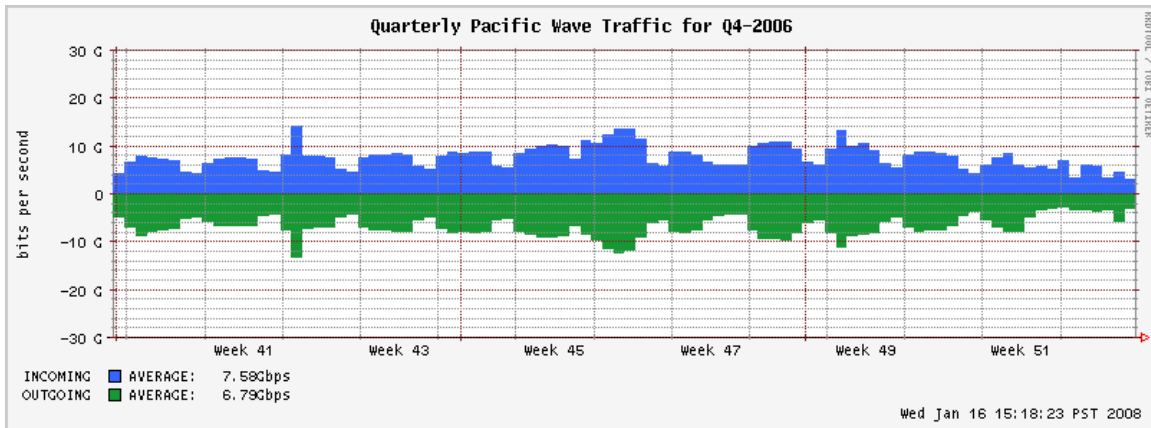

3.4 Outreach Activities

Project Website www.pacificwave.net/participants/irnc/ The project website was updated as new participants were added and to report on other developments.

The PI and other staff from CENIC and PNWG participated in several International meetings and conferences to present about PacificWave activities. A partial list follows.

- The Evolution of Exchange Points, presented at APAN21, Tokyo, Japan, January 24th, 2006.
- Recent Developments in Advanced Networking for Research and Education, Technonet, Northrop Grumman, January 30th, 2006.
- International Networks (and Networking), CENIC'06, Oakland, California, March 13th, 2006.
- Translight/PacificWave Update, Presentation at the International Task Force Meeting, Internet2 Spring Meeting, Arlington, Virginia, April 23rd, 2006.
- International Networks (and Networking), Annual Meeting of the Quilt, New York, October 26th, 2006.
- R&E Networking in the US – a 2006 Update, TIDIA'06, São Paulo, Brasil, November 17th, 2006.
- PacificWave: an Update for APAN23, presented at APAN23, Manila, Philippines, January 23rd, 2007.

In addition, several members of the project are active participants in the organization of APAN and other Pacific related advanced network meetings

3.5 IRNC Review

On October 24-25, 2006, NSF conducted a review of the IRNC projects. In addition to the summary that we reproduced in the overview, the panel had several recommendations which are listed below, followed by our comments.

REVIEW COMMENTS TransLight/Pacific Wave - #0441119 - PI John Silvester,
University of Southern California

The panel recommends that the connections enabled by IRNC to Latin America, specifically the GE connections to CUDI and CLARA be monitored using BCP software, similar to that used by other IRNC programs. Future interconnects in Hawaii should also follow suit. The program should document the overall security practices of PacWave to insure Best Current Practices are being followed to mitigate the risks to the NSF investment. The PIs provided aggregate switching loads for their Ethernet switches rather than per-link data. The number of other providers' switches/routers using the Ethernet service offered by Pacific Wave provides the project with an excellent opportunity to classify data and obtain measurements on eScience usage versus ordinary applications.

The panel was concerned with the lack of information on usage or measurement. While usage and measurement are difficult to accomplish, the panel expected to hear some ideas on how usage could be determined and what types of measurements might be explored. The panel also felt that the project needs to look seriously at security issues associated with their exchange points and operations.

Measurement: Access to measurement data at an exchange point is a challenge since the exchange is not operating any routers and the switches that are deployed are not able to generate necessary information. In addition, most of the networks that participate in the exchange are not willing to agree to measurements and statistics of the traffic on links being made available – rather they suggest that they maintain their own measurement archives that researchers can request access to. We are including some summary statistics of overall exchange traffic. For more detailed measurement of the flows utilizing the facilities on the US side, we consider that the most appropriate way would be through the statistics currently collected by Internet2 and the other US networks that utilize the exchange. We plan to explore this possibility further in year 3 through discussions with the measurement group that is also supported through the IRNC program.

The CUDI and CLARA links are monitored by our sister program WHREN/LILA so no further action is warranted by TransLight/PacificWave. We will enter into discussion with UH as to what monitoring capabilities can be built into the Hawaii side of the connections.

Security: The Exchange facilities operated by PacificWave are located in Commercial Carrier Class facilities that employ rigorous access control and emergency backup

capabilities. The staff having access to the equipment (for configuration, etc) are regular employees of CENIC and the PacificNorthWest GigaPop. Both of these organizations also operate extensive regional networks in the United States and have well trained professional staff that are subject to background checks as part of the hiring process. The Network Operations Facilities of the organizations are staffed 24x7 and have documented procedures for escalation of trouble-tickets and problem resolution. The NOC staff have extensive interactions with other NOC's around the world (including the "Global NOC" at Indiana University that operates the RENISAC) for incident identification and resolution.

4. Activities against Milestones

Listed below are the milestones taken from the SOW updated in the first year Annual Report. Next to each milestone we present commentary on the status of this component of the project. In addition, we mention other activities that have been accomplished during the second year of the project.

[1] Order and install ETE grooming equipment for the Southern Link. Estimated completion of installation in 2nd quarter of year 2. Note that the estimated time for installation of the Sydney equipment by AARNet is the 2nd quarter of year 2.

[2] Test and put into operation the Southern link. Estimated completion by end of 2nd quarter of year 2.

Installation of the Sydney ETE equipment was delayed into year 3 for a variety of reasons unrelated to this project. Consequently, testing and operation of the Sydney-Los Angeles link has been delayed into year 3. The equipment between Hawaii and the US mainland was completed and tested. The backhaul in Hawaii will not be completed until year 3, however, so the link was not put into production in year 2.

[3] Finalize a memorandum of understanding with AARNet for use, support and operation of the links. Finalize the expected use for the Southern link(s). (The southern link is expected to be configured as 8x1GE "lightpaths" or separate channels)

There have been significant discussions on this but no formal MOU has been developed.

[4] Finalize the Los Angeles connections to be put in place. We anticipate connections to Pacific Wave exchange (as a backup for AARNet to the Northern Link); a link for the HI observatory network; a lightpath over Pacific Wave to Canarie; and several project specific links through NLR.

These discussions were moved forward but cannot be considered finalized until the link is actually in operation.

[5] Further discussions with the University of Hawaii for acquisition, location and use of the equipment to be located in Hawaii. In particular, acquisition of a router to increase the flexibility of the configuration is anticipated. Explore opportunities to interlink the Northern and Southern links to increase flexibility and robustness of the design. This will require acquisition of an inter-island link. Discussions with key carriers are underway but it is premature to speculate on how this can be accomplished and what the cost might be. In addition, using leftover year 1 funds, we will explore and implement where feasible ways to enhance connectivity to the observatories on Mauna Kea.

These discussions progressed well and led to planning for adding UH as a sub-award in year 3 to work with Hawaiian Telecom to upgrade the Mauna Kea infrastructure and to develop the

necessary backhaul to connect to the Southern link. Implementation of this plan will be a major activity in year 3 as the Southern link is put into operation.

[6] Develop a sub-contract with the University of Hawaii to acquire, install, and operate necessary equipment in support of the project.

The framework for this sub-contract was developed but implementation was pushed into year 3 since the operation of the S. link was also delayed.

[7] Continue to work with AARNet and University of Hawaii to enable desired peerings in Seattle. Reengineer these peerings as needed.

This is standard operational procedure for the PacificWave NOC. The NOC activated various peerings as requested by participants throughout year 2 of the project.

[8] Work with AARNet and the University of Hawaii to enable desired peerings and connections in Los Angeles. Reengineer these peerings as needed.

Some work was done here but most is delayed until the S. link becomes operational.

[9] Continue to provide NOC service and interaction with other NOC entities (including AARNet NOC and Abilene NOC).

Continued NOC service as required.

[10] Pursue cooperation with other IRNC projects including Transpac2 and Gloriad.

PacificWave worked with all participants including Transpac2 and Gloriad as needed.

[11] Provide support to other R&E networks wishing to connect to Pacific Wave. In particular, pursue discussion with REANNZ in their plans to deploy a link from New Zealand to the US through Pacific Wave. Identify opportunities for collaboration especially in support of applications.

PacificWave worked with REANNZ as they implemented a OC-12 link into a 1G port into the Seattle Exchange point. Completed August 2006.

[12] Work towards providing direct connectivity between Translight/PacificWave and Translight/Starlight to enhance flexibility in supporting connections between US researchers and international collaborators.

TLPW proposed the establishment of this link to CISCO; CISCO responded with a donation of a “CISCO Research Wave” over NLR between Seattle and Starlight (Chicago) for use by PacificWave participants in “Lightpath” experiments. This was put into operation in June 2006.

[13] Extend Pacific Wave to facilitate the connection of the South American networks that participate in the WHREN/LILA IRNC project. In particular, configure and light Ge connection from Los Angeles Exchange to San Diego to connect up with the LILA links from CLARA and CUDI.

[14] Work with CLARA and WHREN/LILA to enable desired peerings and connections in Los Angeles. Reengineer these peerings as needed.

A dark fiber connection between Tijuana and San Diego was leased and switches were deployed at both ends to provide GE connections for CUDI and REDClara. These were backhauled over the CalREN network to the exchange in Los Angeles. These networks then peered with various US and International networks over the exchange fabric.

[15] Deleted was a duplicate.

[16] Develop a series of meetings and workshops as add-ons to existing discipline specific meetings to assist in the deployment of applications that can make effective use of the advanced networking facilities.

Hold a meeting with observatory directors in Hawaii to identify opportunities presented by the network for the observatories located there.

Work with Ocean observatory and Coral Reef projects.

Work with High Energy Physics Community.

Identify opportunities in tele-health and tele-medicine.

In year 2, we entered into discussions with APAC (Australian Partnership for Advanced Computing), REANNZ, and GRIDASIA about the possibility of organizing joint workshops or sessions at their conferences to highlight Science and Engineering research that was enhanced by the use of the facilities supported by TLPW. Plans are in place to run these workshops in year 3 of the project.

[17] Both AARNet and Pacific Wave have extensive measurement capabilities in place. Continue to work with the NSF-designated measurement project to provide these measurements as part of the overall IRNC measurement effort.

PacificWave developed some tools for collection and display of aggregate exchange traffic (some charts from those tools are reported elsewhere in this report and can also be found on the project website.) Several discussions took place, but no real closure was reached on how to address the challenges of collecting useful flow based measurement data at an exchange. We anticipate that these discussions will continue into year 3.

[18] Attend and contribute to IRNC meetings; attend Internet2 and APAN meetings (international).

P.I. and staff from CENIC and PNWG participated in IRNC meetings, attended, helped organize, and gave presentations at both APAN meetings in year 2 of the project.

[19] Request REU support for students to be used to assist in the project.
Not done.

[20] Construct Year 3 program plan in consultation with the IRNC Awardees and NSF.

Plans for the workshops and completion of the S. Link were developed.

[21] Develop more detailed year 4-5 plans as more information on network developments in Asia emerge.

Some progress was made in developing plans for improved connectivity to India. TLPW will work together with Internet2 and Transpac2 as the details emerge. Further effort is needed here.

5. Plan and Proposed Budget for Year 3

5.1 Planned Activities in Year 3

In the third year of the project, we propose to accomplish the following:

1. Continue the operational support for the Pacific Wave exchange, including NOC services, engineering of peering connections as requested, addition of new participants.
2. Complete the build-out of the Southern Link. Implement and test connectivity between the US Mainland and Hawaii; and the US and Australia.
3. As necessary, upgrade the connectivity between the PoP's of PacificWave.
4. Focus on providing support to the Science and Engineering Applications community to enable and facilitate effective use of the advanced networks capabilities provided through IRNC projects in general and TLPW in particular. Organize 2-3 workshops focusing on furthering collaborations. Invite (and cover expenses of) select limited number of US Researchers to participate in these forums.

5. Promote discussion between the US Research and Education Exchange points (US-REX: PacificWave, MANLAN, Starlight, Atlantic Wave) to exchange ideas and experiences and to work together to define services for GOLES.
6. Develop plans for layer 1 and layer 2 services – “Lightpaths” – through PacificWave. NLR has VLAN based lightpaths in operation already and the Internet2 Dynamic Circuit Services are expected to become available toward the end of year 3 (2007). AARnet SX-Transport South is configured as GigE services and several other International R&E Networks are planning to configure part or all of their international connectivity in this fashion.
7. Enhance the connectivity in Hawaii, both to the observatories and between the islands thereby increasing flexibility and robustness. This will be done in close coordination with the University of Hawaii. A sub-contract will be developed to provide the funding for these activities.
8. Increase focus on measurement activities and opportunities. Develop better reporting on use of the exchange by the US Science community.
9. Enhance the security plan and description.
10. Continue discussion with other Pacific-Rim-focused R&E networking activities to identify future synergies and opportunities.

5.2 Proposed Budget for Year 3

[Financial details omitted]

5.3 Detailed Milestones for Year 3

In year 3, we will:

- [1] Complete the installation and test of the ETE grooming equipment for the Southern Link. Estimated completion of installation in 1st quarter of year 3. Test and put into operation the Southern link.
- [2] Finalize the Los Angeles connections to be put in place. We anticipate connections to Pacific Wave exchange (as a backup for AARNet to the Northern Link); a link for the HI observatory network; a lightpath over Pacific Wave to Canarie; and several project specific links through NLR.
- [3] Develop a sub-contract with the University of Hawaii to acquire, install, and operate necessary equipment in support of the project. This will include backhaul from the landing point to Hilo and the Observatory network and upgrade of the Mauna Kea links.
- [4] Work with UH to upgrade connectivity to the Northern link in Oahu to a 10G connection.
- [5] Continue to work with AARNet and University of Hawaii to enable desired peerings in Seattle. Reengineer these peerings as needed. Work with AARNet and the University of Hawaii to enable desired peerings and connections in Los Angeles. Reengineer these peerings as needed.
- [6] Continue to provide NOC service and interaction with other NOC entities (including AARNet NOC and Abilene NOC).
- [7] Pursue cooperation with other IRNC projects including Transpac2, Gloriad and WHREN/LILA.

- [8] Provide support to other R&E networks wishing to connect to Pacific Wave.
- [9] Work towards continuation of the CISCO research wave award between Seattle and Chicago. Explore extension of this connection to Washington DC and perhaps to MANLAN.
- [10] Organize a meeting of the US Research and Education Exchange operators (US-REX) to discuss plans and opportunities for GOLE and lightpath operations.
- [11] Work with PacificWave participants including AARNet, CLARA, CUDI, GLORIAD, Internet2, NLR, to enable desired peerings and connections in Los Angeles and Seattle. Reengineer these peerings as needed.
- [12] Develop a series of meetings and workshops as add-ons to existing discipline specific meetings to assist in the deployment of applications that can make effective use of the advanced networking facilities. In particular, organize an add-on session at GRIDASIA; participate in the planning and participate in the REANNZ First Annual Meeting; and develop a 1.5 day workshop as an add-on to the APAC meeting in Perth Australia. This workshop has a tentative working title of “Developing e-Research Capabilities across the Pacific” (DeRCAP).
- [13] Hold a meeting with observatory directors in Hawaii to identify opportunities presented by the network for the observatories located there.
- [14] Continue to work with the NSF-designated measurement project to provide these measurements as part of the overall IRNC measurement effort.
- [15] Record and identify the value of the project to the US Science and Engineering community.
- [16] Develop a more detailed security plan.
- [17] Attend and contribute to IRNC meetings; attend Internet2 and APAN meetings (international).
- [18] Construct Year 4 program plan in consultation with the other IRNC Awardees and NSF.
- [19] Develop more detailed year 5 plan and as more information on network developments in Asia emerge. Start to plan for follow-on and continuity planning beyond this phase of the IRNC program.